

Clarke®

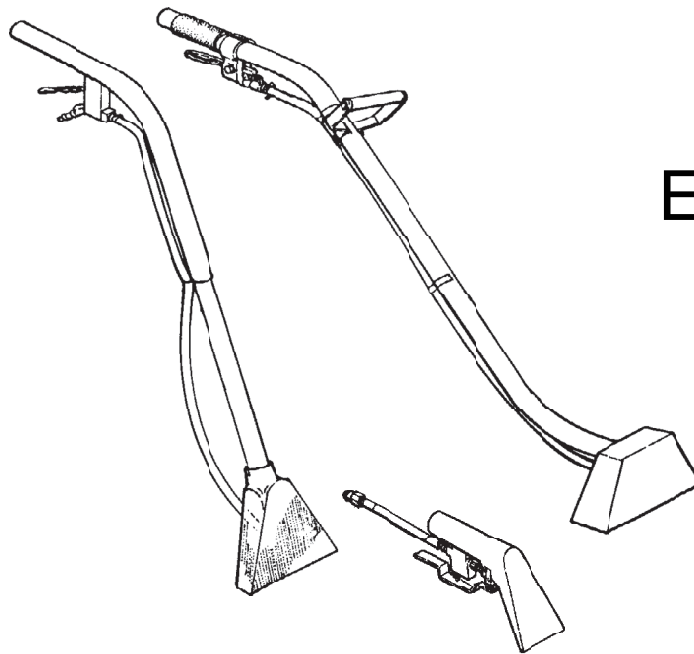

Extractor Tools

Operator's Manual and Parts List

ACTIVE MODEL: 59228A

OBSOLETE MODELS: 59231A, 59230A, 59229A

READ THIS BOOK

This book has important information for the use and safe operation of this machine. Failure to read this book prior to operating or attempting any service or maintenance procedure to your Clarke machine could result in injury to you or to other personnel; damage to the machine or to other property could occur as well. You must have training in the operation of this machine before using it. If your operator(s) cannot read this manual, have it explained fully before attempting to operate this machine.

All directions given in this book are as seen from the operator's position at the rear of the machine.

CONTENTS OF THIS BOOK

Operator Safety Instructions	3
Introduction	4
How to Operate the 4" Floor Tool.....	4
How to Operate the 8" and 12" Floor Tool	5
.....	
How to Clean the Carpet	6
Maintenance	7
4" Plastic Hand Tool Assembly Drawing and Parts List	8
4" Metal Hand Tool Assembly Drawing & Parts List.....	9
8" Plastic Wand Assembly Drawing & Parts List.....	10
12" Metal Wand Assembly Drawing & Parts List	11

OPERATOR SAFETY INSTRUCTIONS



WARNING



AVERTISSEMENT



ADVERTENCIA

For the safe operation of these tools, read and understand all warnings and cautions.



DANGER means: Severe bodily injury or death can occur to you or other personnel if the **DANGER** statements found on your machine or in your Owner's Manual are ignored or are not adhered to. Read and observe all **DANGER** statements found in your Owner's Manual and on your machine.



WARNING means : Injury can occur to you or to other personnel if the **WARNING** statements found on your machine or in your Owner's Manual are ignored or are not adhered to. Read and observe all **WARNING** statements found in your Owner's Manual and on your machine.



CAUTION means: Damage can occur to the machine or to other property if the **CAUTION** statements found on your machine or in your Owner's Manual are ignored or not adhered to. Read and observe all **CAUTION** statements found in your Owner's Manual and on your machine.



DANGER: Tools can cause an explosion when operated near flammable materials and vapors. Do not use these tools with or near fuels, grain dust, solvents, thinners, or other flammable materials.



WARNING: You must have training in the operation of these tools before using them. **READ THE INSTRUCTION BOOK FIRST.**



WARNING: Do not use this tool as a step or furniture.



WARNING: Maintenance and repairs must be done by authorized personnel only.



WARNING: Keep all fasteners tight. Keep the adjustments according to specifications.



WARNING: Make sure that all the labels, decals, warnings, cautions and instructions are fastened to the tool. Replace them when necessary by ordering them from Clarke Technology.



WARNING: Do not use water that is hotter than 140°F.



NOTICE: For safety, **READ** and **OBEY** the **INSTRUCTIONS** given in the Owner's Manual for the extractor that is used with these tools.

INTRODUCTION

The extractor tools are tools for cleaning the carpet. When used with an extractor, the tools apply cleaning solution to the carpet, and removes dirty solution and soil from the carpet.

- Use the 4" metal and 4" plastic hand tools to clean stairs and small areas of carpet. These tools clean a path 3-1/2 inches wide.
- Use the 8" plastic wand and 12" metal wand to clean edges of a room and larger areas of carpet. The 8" wand cleans a path 8 inches wide. The 12" wand cleans a path 12 inches wide.
- The extractor has controls to start the pump for the solution and the motor for the vacuum. The floor tool has a control to release the solution.

How To Operate The 4" Hand Tools

NOTE: Instructions for preparation and operation of your extractor are given with the extractor.

 **CAUTION:** Clarke will not be held liable for damage to the carpet, or poor results because of operator's lack of training.

To operate the 4" hand tools, follow this procedure:

1. Connect the vacuum hose to the hose connector on the extractor and to the end of the vacuum tube on the floor tool.
2. Connect the solution hose to the extractor and the floor tool. To fasten the quick-disconnect, slide the knurled collar on the female coupling away from the opening. Push the male coupling into the female coupling.
3. The switch that activates the motor for the pump is on the extractor. Put the switch in the "ON" position.
4. The switch that activates the motor for the vacuum is on the extractor. Put the switch in the "ON" position.
5. Begin at the right-hand corner of the area to be cleaned.
6. Press the solution release lever. Pull the tool toward you at a slow steady speed.

How To Operate The 8" and 12" Wands

NOTE: Instructions for preparation and operation of your extractor are given with the extractor.

 **CAUTION:** Clarke will not be held liable for damage to the carpet, or poor results because of operator's lack of training.

 **CAUTION:** Do not use water that is hotter than 140°F.

To operate the 8" and 12" wands follow this procedure:

1. Connect the vacuum hose to the hose connector on the extractor and to the end of the vacuum tube on the floor.
2. Connect the solution hose to the extractor and the floor tool. To fasten the quick-disconnect slide the knurled collar on the female coupling away from the opening. Push the male coupling into the female coupling.
3. The switch that activates the motor for the pump is on the extractor. Put the switch in the "ON" position.
4. The switch that activates the motor for the vacuum is on the extractor. Put the switch in the "ON" position.
5. Move the floor tool to the right-hand corner of the carpet.
6. Hold the floor tool at an angle that gives the best seal between the tool to increase the seal.
7. Press down on the tool to increase the seal.
8. Press the solution release lever.
9. Move backwards and pull the tool toward you at a rate of about 30 feet per minute. Move slower for very dirty areas.
10. Release the solution lever approximately six inches before you stop moving backward.
11. Lift the wand and move it to the side of the starting point.
12. To clean the edge of a room, move the wand along the baseboard.

How To Clean The Carpet

 **WARNING:** When using the tools and the extractor to clean, make sure this procedure is followed.

1. Do not walk on freshly cleaned carpet for at least four hours or until the carpet is dry to the touch.
2. Do not remove aluminum or plastic pieces that have been placed under the legs of the furniture until the carpet is dry.
3. Do not allow children or pets to crawl or walk around on the damp carpet.

How To Clean A Small Area Of Carpet

To clean a small area of carpet, follow this procedure:

1. Clean the carpet in sections of three feet square.
2. As you make a pass, repeat one inch of the area already cleaned.
3. To remove more liquid from the carpet, make passes over the area already cleaned. Do not press the solution lever.

How To Clean A Large Area Of Carpet

To clean a large area of carpet follow this procedure:

1. Begin at the right-hand corner of the carpet.
2. Make a pass halfway along the edge of the carpet. Pull the tool back at a steady speed.
3. Move to the edge of the carpet. Make another pass next to your first pass.
4. As you make more passes, repeat one inch of the area already cleaned. Make each pass four inches different in length to prevent making a line in the center of the carpet.
5. Make more passes until half of the carpet is cleaned.
6. Move to the right-hand corner of the part of the carpet not yet to be cleaned.
7. Make a pass halfway along the edge of the carpet.
8. As you make more passes, repeat one inch of the area already cleaned.
9. Make more passes until all of the room is cleaned.

MAINTENANCE

After each use of the tools, do the following:

1. Use clean water from the extractor to flush the solution system of each of the tools.
2. Disconnect the solution hose and the vacuum hose from the machine.
3. To drain the solution system, press the pin in the male connector for the solution hose. Press the solution release lever.
4. Check for objects in the vacuum opening. Use a stick to remove any objects from the vacuum opening.
5. Check for leaks at all connections.
6. Apply a small amount of silicone lubricant to the quick-disconnect fittings. To prevent damage to the O-rings, do not use an oil lubricant.
7. Check the spray jets on the floor tools. If a spray jet is not working correctly, use this procedure to clean the jet:
 - a. Remove the jet from the machine and put it in a solution of ammonia and water.
 - b. Blow compressed air through the jet and install the jet on the tool.



CAUTION: To prevent damage to the spray jet, do not push a wire or any object through the opening in the jet.

8. Use a dry cloth to wipe the tool.

**CLARKE 4" Plastic Hand Tool
59231A (Obsolete)**

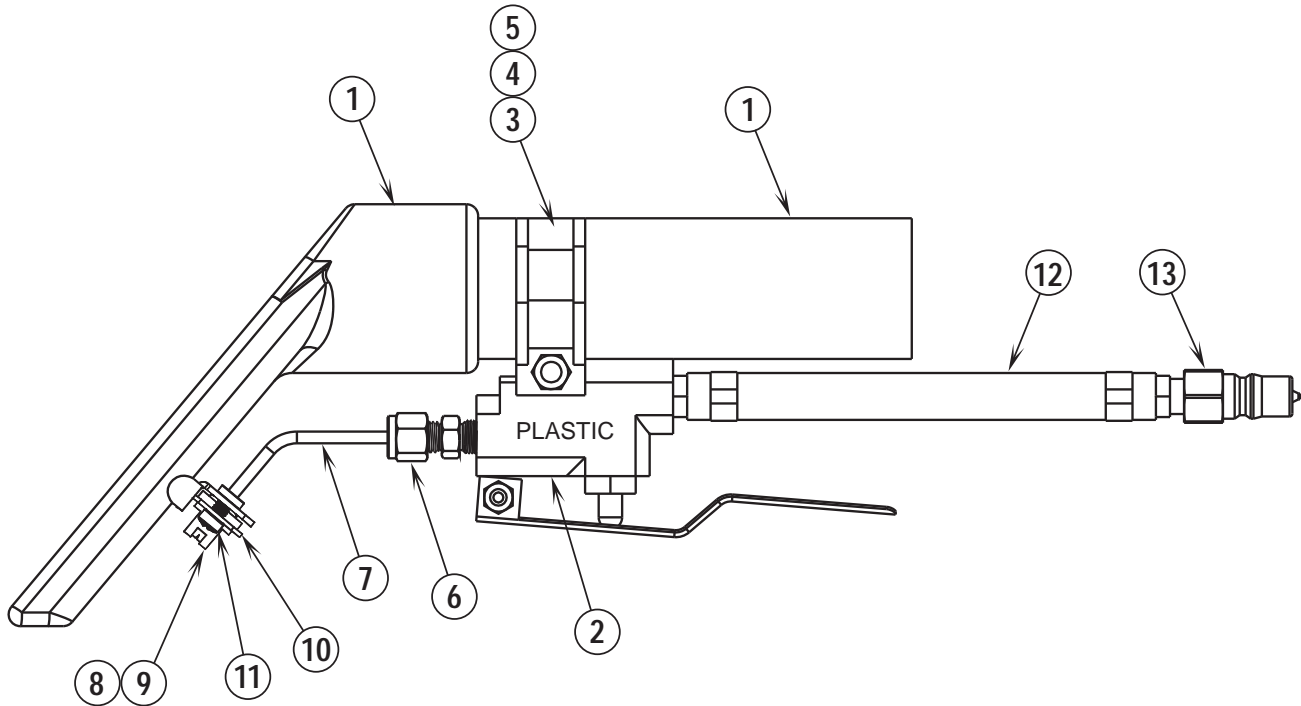

Item	Ref. No.	Qty	Description
1	55179A	1	Plastic Head w/tube 1-1/2"
2	59618A	1	Valve Assembly, Plastic
3		2	VS Valve Hanger 1-1/2"
4		1	Screw, S.S. Pan Hd 10-32 x 1-1/4"
5		1	Nut, S.S. Hex 10-32
6	54060A	1	Tube Comp., 1/8 MPT x 3/16" Ferrule
7		1	Manifold
8	54177A	1	Tee Jet, Plastic Orange
9		1	O-Ring, 7/16" O.D. x 5/16" I.D.
10		1	Retainer Plate
11	962802	2	Screw, 8-32 x 1/4" S.S. Fillister Hd.
12	55180A	1	Hose Assembly, Solution
13	374	1	Quick Connector, 1/8 FPT Male

CLARKE 4" Metal Hand Tool 59228A

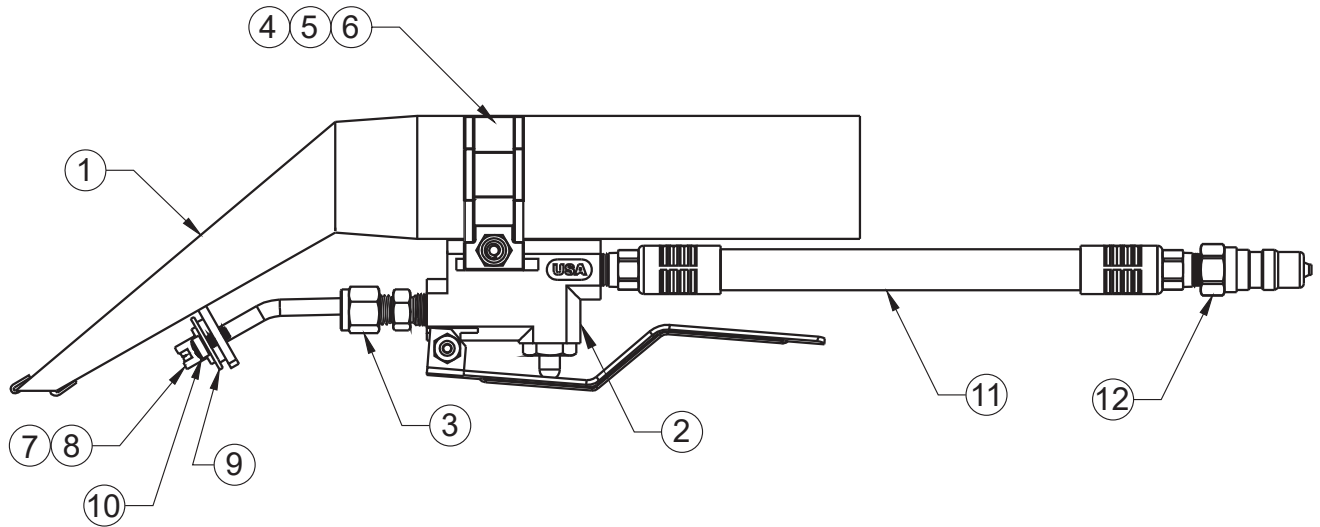

Item	Ref. No.	Qty	Description
1		1	Head Assembly (Metal)
2#	338USP	1	Valve Aluminum 400psi For Ht
3	54060A	1	Tube Comp., 1/8 MPT x 3/16" Ferrule
4		2	VS Valve Hanger 1-1/2
5		1	Screw, S.S. Pan Hd 10-32 x 1-1/4"
6		1	Nut, S.S. Hex 10-32
7	54177A	1	Tee Jet
8		1	O-Ring, 3/8 O.D. x 1/4 I.D.
9		1	Retainer Plate
10	962802	2	Screw, 8-32 x 1/4" Fillister Hd.
11	55180A	1	Hose Assembly, Solution
12	374	1	Quick Conn., 1/8 FPT Male

= Revised or new since last update

**CLARKE 8" Plastic Wand Assembly
59230A (Obsolete)**

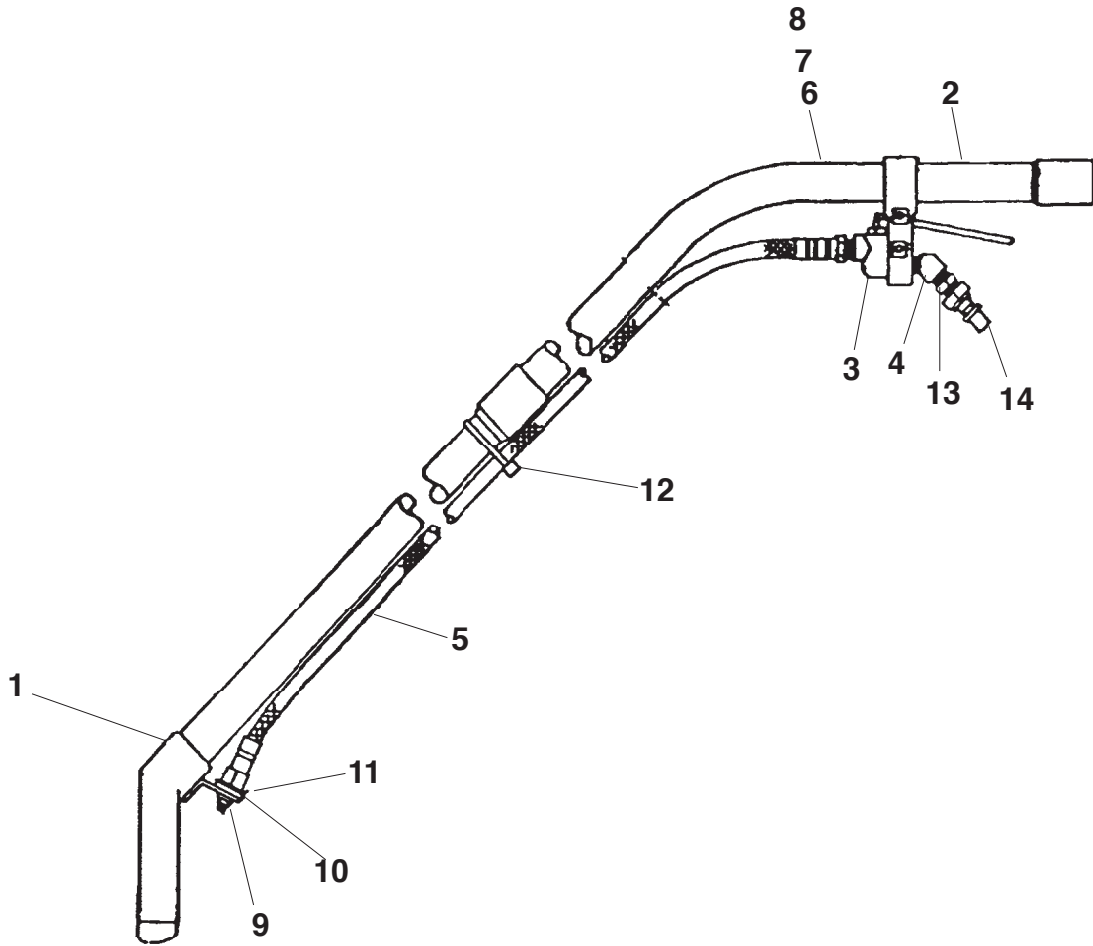

Item	Ref. No.	Qty	Description
1	50383A	1	Head and Tube Assembly
2		1	Upper Tube
3	59616A	1	Valve Assembly, Plastic
4		1	Elbow, 45° Street
5		1	Hose, Solution 38"
6	55177A	2	Valve Hanger, 1-1/4" Cast Aluminum
7		2	Screw, Pn Hd 10-32 x 1-1/4 S.S.
8		2	Nut, S.S. Hex 10-32
9	30044A	1	Nozzle, 1/4 (2 x 80°)
10		1	Washer, Plastic
11		1	Washer, Flat 9/16 SS
12	58901A	1	Cable Tie, 3/16" Black
13		1	Nipple, 1/4 MPT x 1/8 MPT Hex
14	374	1	Quick Connector, 1/8 FPT Male

CLARKE 12" Metal Wand Assembly 59229A (Obsolete)

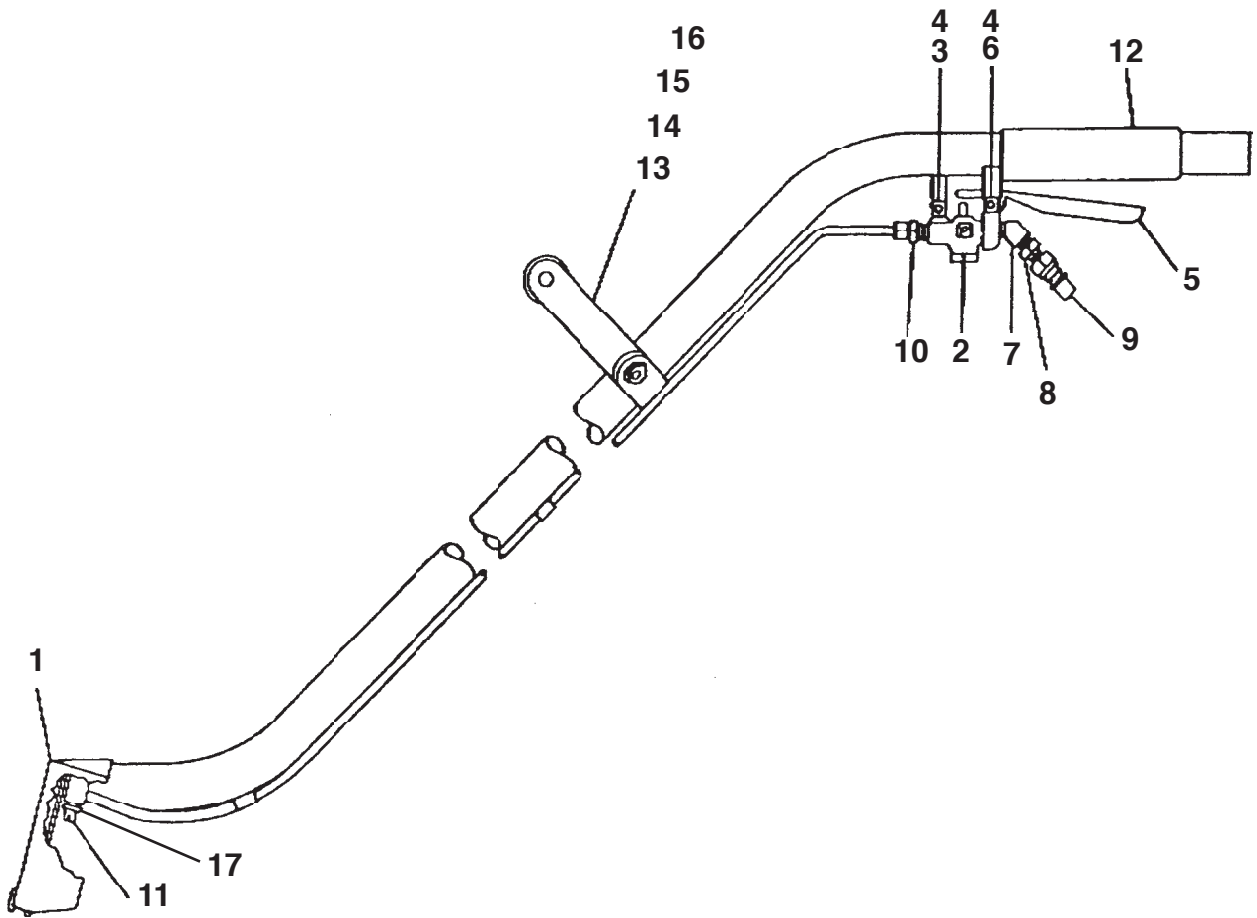

Item	Ref. No.	Qty	Description
1	59890A	1	Wand Assembly
2	59615A	1	Valve Assembly
3	85307A	1	Screw, S.S. Pan Hd 10-32 x 5/8"
4	920722	2	Nut, S.S. Nylock 10-32
5	55809A	1	Lever Valve
6		1	Screw, S.S. Pan Hd. 10-32 x 1-1/8"
7		1	Elbow, 45° Street
8	697501	1	Nipple, 1/4 MPT x 1/8 MPT Hex
9	374	1	Quick Connector, 1/8 FPT Male
10	54061A	1	Tube Comp. Ferrule, 1/4 MPT x 1/4"
11	54174A	2	Vee Jet, 1/4 MPT Brass
12		1	Grip, Vinyl 6" x 1-1/2" Dia.
13		1	Handle Assembly
14	54934A	1	Handle Back
15	962139	2	Bolt, S.S. 1/4-20 x 5/8"
16	920208	2	Nut, S.S. Hex 1/4-20
17	30184A	2	Strainer, Spray Jet

Clarke[®]

9435 Winnetka Ave North
Minneapolis, MN 55445

www.clarkeus.com

Phone: 800-253-0367

Fax: 800-825-2753

©2018 Nilfisk, Inc.

A Nilfisk Brand