Clarke®

Operator's Manual

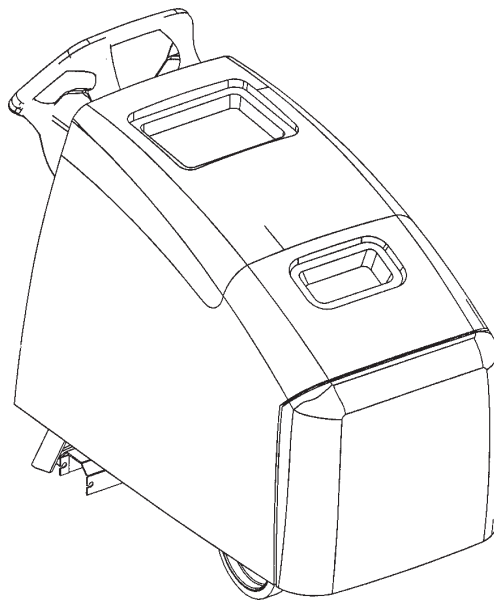

IMAGE 26B WASH & RINSE®

READ THIS BOOK

This book has important information for the use and safe operation of this machine. Failure to read this book prior to operating or attempting any service or maintenance procedure to your Clarke machine could result in injury to you or to other personnel; damage to the machine or to other property could occur as well. You must have training in the operation of this machine before using it. If your operator(s) cannot read English, have this manual explained fully before attempting to operate this machine.

Si Ud. o sus operadores no pueden leer el Inglés, se hagan explicar este manual completamente antes de tratar el manejo o servicio de esta máquina.

All directions given in this book are as seen from the operator's position at the rear of the machine.

For new books write to: Clarke®, 2100 Highway 265, Springdale, Arkansas 72764.

CONTENTS OF THIS BOOK

Operator Safety Instructions	3
Introduction and Machine Specifications	5
Transporting the Machine	6
Machine Controls	7
How to Prepare the Machine for Operation	10
Machine Operating Instructions	14
Maintenance Instructions	17

SECTION II PARTS AND SERVICE

How to Correct Problems in the Machine	20
Recovery Tank and Hose Assembly	21
Handle Assembly	22
Rear Panel Assembly	23
Solution Tank Assembly	24
Solution Delivery System	25
Frame Assembly	26
Battery Tray	27
Recovery Tool Assembly	28
Brush Assembly	29
Transaxle Parts List	30
Vac Motor Assembly	31
Battery Charger (40506A, 40507A, 40505A)	32
Battery Charger (40512B, 40506B)	33
Available Accessories	34
Wiring Schematic	35
Connection Diagram	36
Flow Diagram	37

OPERATOR SAFETY INSTRUCTIONS



WARNING



AVERTISSEMENT



ADVERTENCIA



DANGER:

Failure to read and observe all **DANGER** statements could result in severe bodily injury or death. Read and observe all **DANGER** statements found in your Owner's Manual and on your machine.



WARNING:

Failure to read and observe all **WARNING** statements could result in injury to you or to other personnel; property damage could occur as well. Read and observe all **WARNING** statements found in your Owner's Manual and on your machine.



CAUTION:

Failure to read and observe all **CAUTION** statements could result in damage to the machine or to other property. Read and observe all **CAUTION** statements found in our Owner's Manual and on your machine.



DANGER:

Failure to read the Owner's Manual prior to operating or attempting any service or maintenance procedure to your Clarke machine could result in injury to you or to other personnel; damage to the machine or to other property could occur as well. You must have training in the operation of this machine before using it. If your operator(s) cannot read English, have this manual explained fully before attempting to operate this machine.



DANGER:

Operating a machine that is not completely or fully assembled could result in injury or property damage. Do not operate this machine until it is completely assembled. Inspect the machine carefully before operation.



DANGER:

Machines can cause an explosion when operated near flammable materials and vapors. Do not use this machine with or near fuels, grain dust, solvents, thinners, or other flammable materials. This machine is not suitable for picking up hazardous dust.



DANGER:

Lead acid batteries generate gases which can cause an explosion. Keep sparks and flames away from batteries. Do not smoke around the machine. Charge the batteries only in an area with good ventilation. Make sure that the AC charger plug is unplugged from the wall receptacle before connecting or disconnecting the DC plug to or from the battery pack.



DANGER:

Working with batteries can be dangerous! Always wear eye protection and protective clothing when working near batteries. Remove all jewelry. Do not put tools or other metal objects across the battery terminals, or the tops of the batteries.



DANGER:

Using a charger with a damaged power cord could result in an electrocution. Do not use the charger if the power cord is damaged.



WARNING:

Operating this machine from anywhere other than the back of the machine could result in injury or damage. Operate this machine only from the rear.















WARNING:

This machine is heavy. Get assistance before attempting to transport or move it. Use two able persons to move the machine on a ramp or incline. Always move slowly. Do not turn the machine on a ramp. If operating machine on a gradient over 2%, do not stop, turn or park. Read the "Procedures For Transporting" in this manual before transporting as machine might topple over if not strapped.



WARNING:

Machines can topple over if guided over the edges of stairs or loading docks and cause injury or damage. Stop and leave this machine only on a level surface. When you stop the machine, put all switches into their "OFF" position.

-  **WARNING:** This machine is not equipped with a parking brake. Never leave the machine unattended. For added safety, always place a chock in front of and behind the drive wheel.
-  **WARNING:** Maintenance and repairs performed by unauthorized personnel could result in damage or injury. Maintenance and repairs must be performed by authorized Clarke personnel only.
-  **WARNING:** Any alterations or modifications of this machine could result in damage to the machine or injury to the operator or other bystanders. Alterations or modifications not authorized by the manufacturer voids any and all warranties and liabilities.
-  **WARNING:** Electrical components of this machine can "short-out" if exposed to water or moisture. Keep the electrical components of the machine dry. Wipe the machine down after each use. For storage, keep the machine in a dry building.
-  **WARNING:** Operating a machine without observing all labels and instructional information could result in injury or damage. Read all machine labels before attempting to operate. Make sure all of the labels and instructional information are attached or fastened to the machine. Get replacement labels and decals from your Clarke distributor.
-  **WARNING:** Wet floor surfaces can be slippery. Water solutions or cleaning materials used with this type of machine can leave wet areas on the floor surface. These areas can cause a dangerous condition for the operator or other persons. Always put "Caution" signs around/near the area you are cleaning.
-  **WARNING:** Improper discharge of waste water may damage the environment and be illegal. The United States Environmental Protection Agency has established certain regulations regarding discharge of waste water. Also, city and state regulations regarding this discharge may be in effect in your area. Understand and follow the regulations in your area. Be aware of the environment hazards of chemicals that you dispose.
-  **WARNING:** Using water that is above 140°F can damage the machine. Do not use water where the temperature is above 140°F.
-  **WARNING:** To avoid personal injury to operators or bystanders, do not operate machine at full traverse speed down inclines. Machine is heavy and can cause personnel injury and property damage.
-  **CAUTION:** Your machine warranty will be voided if anything other than genuine Clarke parts are used on your machine. Always use Clarke parts for replacement.
-  **CAUTION:** Use of this machine to move other objects or to climb on could result in injury or damage. Do not use this machine as a step or furniture. Do not ride on this machine.
-  **CAUTION:** Carpet damage can occur if carpet has not adequately dried before traffic resumes. Stay off the carpet until it is dry.

INTRODUCTION AND MACHINE SPECIFICATIONS

The **IMAGE 26B** is a one-piece, self-propelled carpet extractor designed for cleaning carpet. The machine applies cleaning solution to the carpet and then removes the dirty solution and soil with a recovery tool.

Features:

- ◆ Easy to Operate
- ◆ Interex cleaning system.
- ◆ Brush pressure gauge.
- ◆ Variable speed transaxle (forward and reverse)
- ◆ Adjustable brush pressure.
- ◆ Adjustable traverse speed.
- ◆ Rugged 10-gauge mainframe.
- ◆ Large capacity, compact size.
- ◆ Easy access for serviceability.
- ◆ Large recovery tank opening for easy cleaning.
- ◆ Smooth 10", non marking, tread-less drive wheels.
- ◆ Accessory tool connection.
- ◆ No fatigue, dead man switch mounted on control handle.
- ◆ Dual tangential discharge vac motors
- ◆ Circuit breaker protection for traverse, brush, pump and vac motors.
- ◆ Automatic shut-off when recovery tank is full.
- ◆ Adjustable bypass pump.
- ◆ Solution level indicator.
- ◆ Low voltage battery protection (solution and brush stop when low voltage condition occurs)

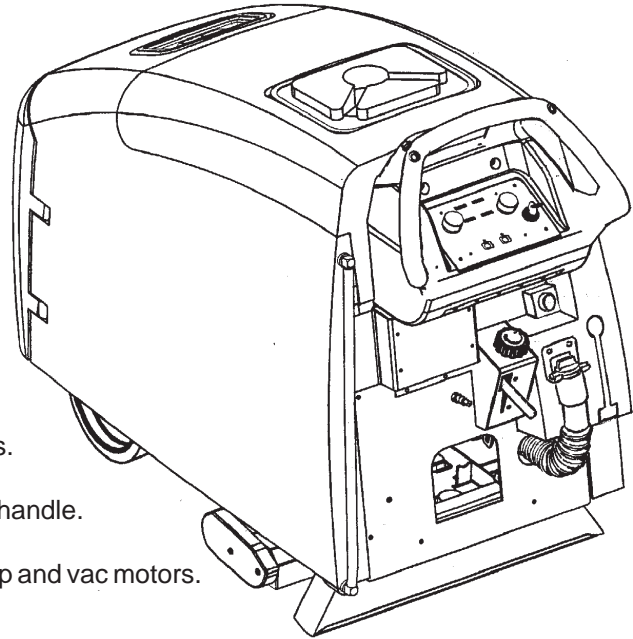



IMAGE 26B, 36V	
Solution Pump	100 psi Adjustable By-pass
Solution Tank Capacity	30 Gallon
Recovery Tank Capacity	30 Gallon
Water Lift	76" Functional WL 150/CFM
Vacuum	2 Tangential discharge, three-stage motors
Batteries	3 12V 195AH Batteries
Spray Jets	Quick Change Nozzles
Brush Size	4" x 23"
Dimensions	48" x 26" x 43"
Weight (w/batteries)	650 lbs.
Shipping Weight	922 lbs.
Dimensions	56" x 28" x 46" (41.7 cu. ft.)

TRANSPORTING THE MACHINE

How to Put the Machine in a Van or Truck

 **WARNING:** The machine is heavy. Make sure you use two able persons to help assist the machine up the ramp.

1. Make sure the loading ramp is no less than eight feet long and strong enough to support the machine.
2. Make sure the ramp is clean and dry.
3. Secure the ramp in position.
4. Lift the brush assembly into an upright position.
5. Align the machine on a level surface ten feet in front of the ramp.
6. Push the machine to the top of the ramp.
7. Tie down the machine.

How to Remove the Machine From A Van Or Truck

1. Make sure there are no obstructions in the area.
2. Make sure the unloading ramp is no less than eight feet long and strong enough to support the machine.
3. Make sure the ramp is clean and dry.
4. Secure the ramp in position.
5. Untie the machine.

 **WARNING:** The machine is heavy. Make sure you use two able persons to assist the machine down the ramp.

6. Assisting the machine down the ramp, position yourself to maintain a slow downward speed.

THE CONTROLS

Key Switch (See figure 1, A)

The key switch is located on the control panel.

The key switch must be on before any function of the machine will work. Turn to "O" for OFF and "I" for ON.

Battery Meter (See figure 1,B)

The battery meter indicates the relative charge on the battery pack. Do not continue to run the machine when the meter is in "red" area. This will shorten the life of the battery. **NOTE:** Low voltage will shut off solution and brush functions. Recover remaining solution and return to charge station.

The Traverse Knob (See figure 2, A)

The traverse knob is located on the left side of the control panel. The traverse knob controls the speed of the machine. For faster speeds, turn the knob to the right. For slower speeds, turn the knob to the left. Light bars indicate traverse speed. Twenty feet per minute is optimum cleaning speed.

The Traverse Meter (See figure 2, B)

The lights on the meter indicate the cleaning range. Speeds in the 1 to 10 light range indicate cleaning speeds for various conditions. Speeds above those indicated by the tenth light are used only for traversing to dumping, filling or charging locations.

Variable Pump Pressure (See figure 2, C)

The control knob is located on the right side of the control panel. The control knob can be adjusted clockwise to increase flow and pressure or counterclockwise to decrease flow and pressure. If streaking occurs increase pressure setting.

⚠ WARNING: Do not operate the pump if the solution tank is empty. Damage to the pump could occur.

The Vacuum Switch

The vacuum switch is activated by the recovery tool lift handle. The vacuum motors are switched on when the tool is lowered. The vac motors are switched off after a 10 second delay when the tool is raised.

Accessory Vac Switch (See figure 3,A)

The accessory vac switch is located on the lower left side of the control panel. This switch turns on the vac motors when the recovery tool is raised. This allows the use of accessory tools when connected to the recovery hose.

Pump Switch (See figure 3,B)

The pump switch allows the pump to be turned off when solution application is not required.

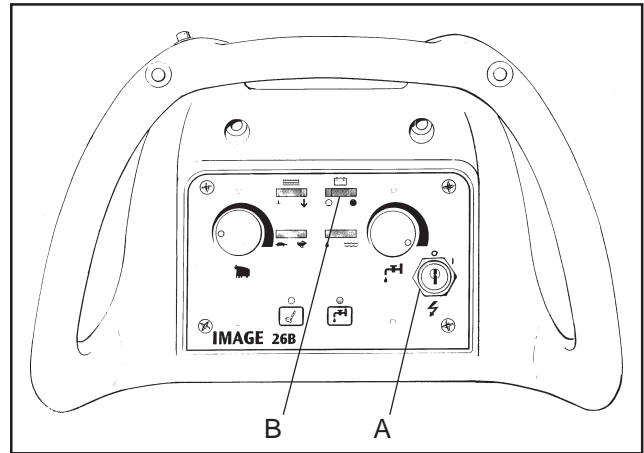

Figure 1

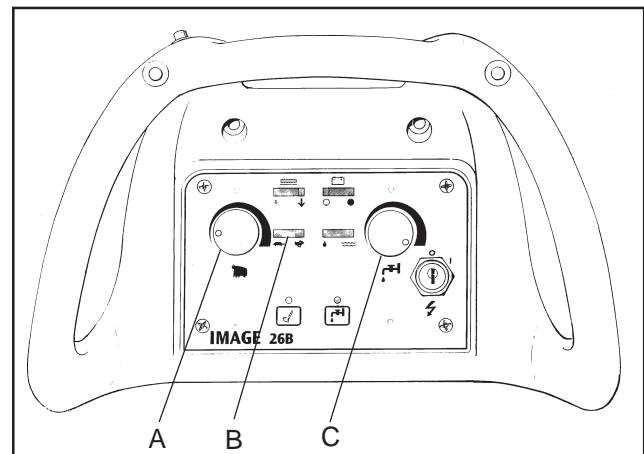

Figure 2

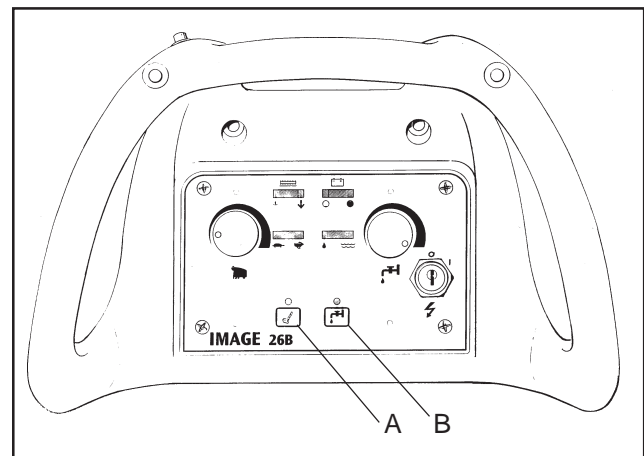

Figure 3

THE CONTROLS (cont.)

The Brush Adjustment Control Knob (See figure 4, A)

The brush lift control knob is located at the rear of the machine. The knob is adjustable for many types of carpet. This setting need not be adjusted between uses. The settings are retained.

Brush Pressure Meter

The brush pressure meter indicates the relative amount of pressure the brush is putting on the floor. To maximize run time on a battery charge, keep the light bars towards the center of the green area. To avoid damage to the brush motors, do not run the machine in the "red" area.

The Recovery Tool Handle (See figure 5, A)

The recovery tool handle is located on the back of the machine. This handle lowers the recovery tool and brush.

Accessory Hose Connector (See figure 6, A)

The accessory hose connector is used to hook-up optional auxiliary floor tools and to redirect the solution flow. Use hose coupler (P.N. 30108A) to connect accessory hose to recovery shoe hose.

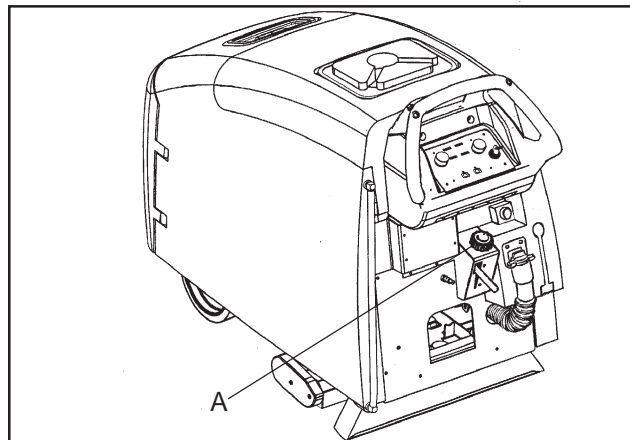

Figure 4

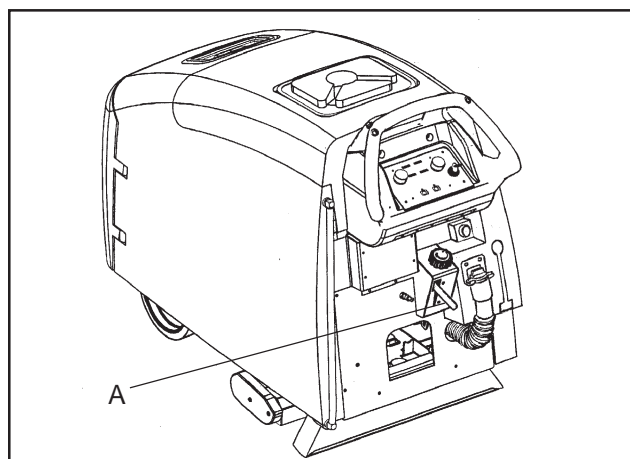

Figure 5

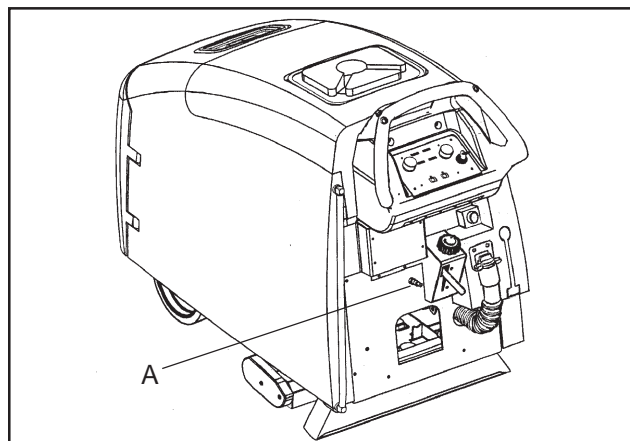

Figure 6

THE CONTROLS

The Traverse Switch (See figure 7, A)

The traverse switch is located on the control handle. Light pressure with the thumb or hand activates the traverse for forward movement.

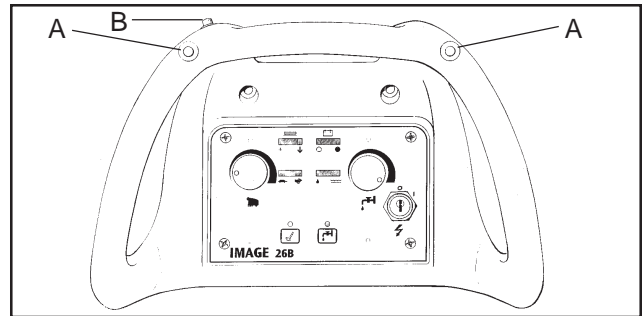

Figure 7

The Reverse Switch (See figure 7, B)

The reverse switch is the white button located on top of the handle. Reverse traverse is achieved by simultaneously pressing the traverse and reverse buttons.

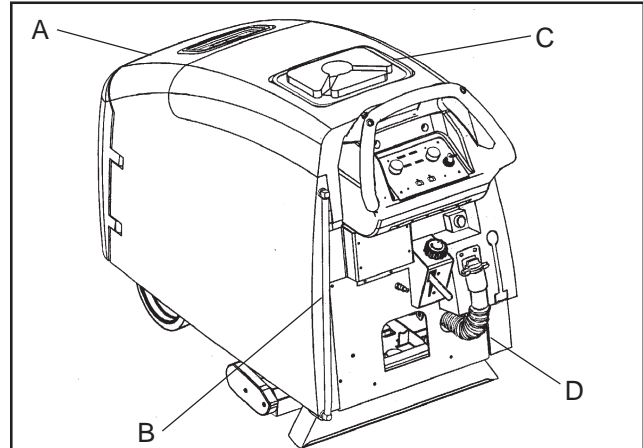

Figure 8

Solution Tank (See figure 8, A)

The solution tank is top center of the machine. The solution tank fill opening is located in the center of the tank at the front of the machine.

Solution Tank Drain Hose and Solution Level Indicator (See figure 8,B)

The solution drain hose is on the lower left at the back of the machine. To drain, pull the clear hose free of the top hosebarb and lay the hose into drain. Reconnect when finished.

Recovery Tank (See figure 8, C)

The recovery tank is mounted in the rear center position on the machine.

Recovery Tank Drain Hose (See figure 8, D)

The recovery drain hose is located at the center right at the back of the machine.

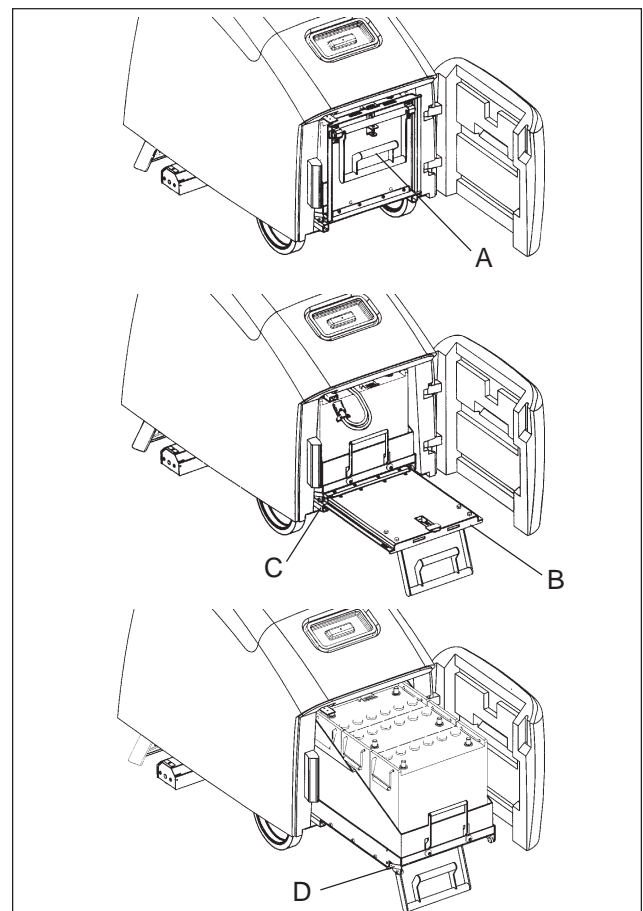

Figure 8

Battery Tray (See figure 9, A-C)

The battery tray must be pulled out of the machine on the front bridge in order to change batteries or check electrolyte. To lower bridge, grasp handle and pull up firmly to insure handle is extended fully (A). Lower bridge (B). Release lever on left side of battery tray (C) and pull tray out slowly until latch arm engages in slot on bridge (D). To return battery tray to operating position, release lever and slide tray back into machine until lever engages in frame. Raise and latch bridge. Close front.

HOW TO PREPARE THE MACHINE FOR OPERATION

The Image 26B uses three 12-Volt batteries. The batteries are located on a battery tray that can be accessed by opening the front cover and lowering the front bridge. To install the batteries, follow this procedure:

1. Turn key switch off.
2. Make sure both tanks are empty.
3. Place the batteries in the battery tray as shown in figure 10.

WARNING: Lifting batteries without help could result in an injury. Get help to lift the batteries. The batteries are heavy.

WARNING: Working with batteries can be dangerous. Always wear eye protection and protective clothing when working near batteries. **NO SMOKING!**

4. Connect the battery cables between batteries and install long battery cable assembly as indicated. See figure 10.
5. Join the connector from the battery pack to the connector on the front of the machine. Raise and latch front bridge and close front cover. See figure 11, A.

NOTE: Charge the batteries before using the machine.

Battery Maintenance

The electrical power to operate the machine comes from the storage batteries. Storage batteries need preventative maintenance.

To maintain the batteries in good condition, follow these instructions:

1. Keep the electrolyte at the correct level. The correct level is between 1/4" below the bottom of the tube in each cell and above the tops of the plates. Check the level of the electrolyte each time you charge the batteries. See figure 12.

NOTE: Check the level of electrolyte prior to charging the batteries. Be sure the plates in each cell are covered with electrolyte. Do not top off the cells prior to charging the battery. Electrolyte expands during charging. As a result, the electrolyte could overflow from the cells. Always top off the cells with distilled water after charging.

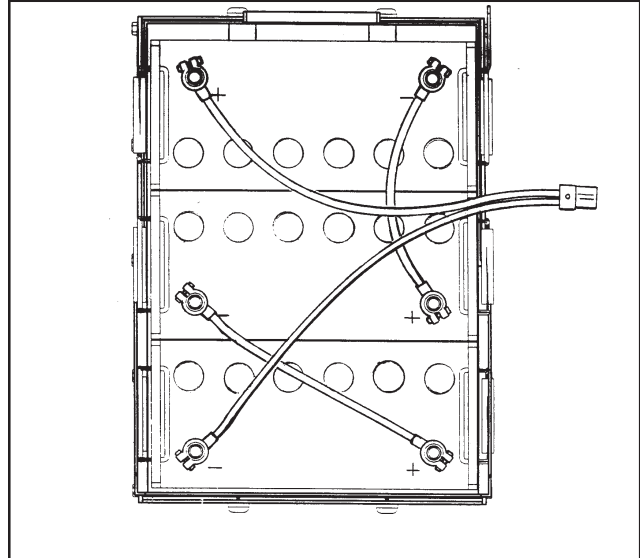

Figure 10

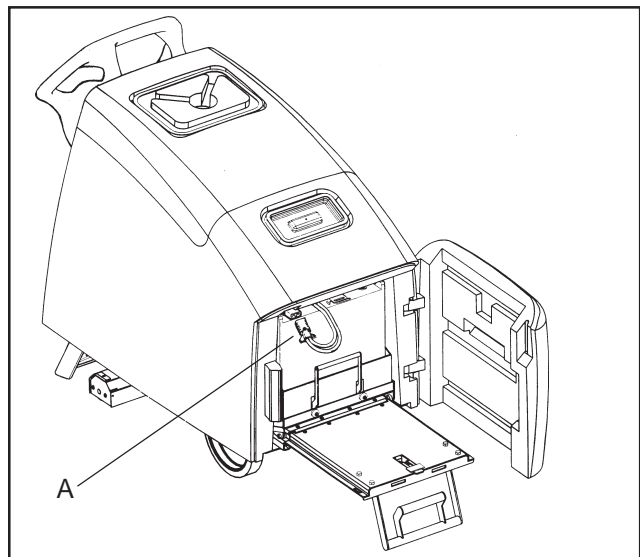

Figure 11

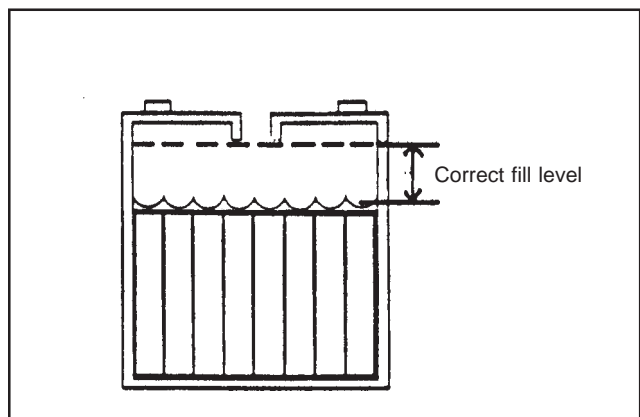







Figure 12

HOW TO PREPARE THE MACHINE FOR OPERATION

-  **CAUTION:** Irreversible damage will occur to the batteries if the electrolyte level does not cover the plates. Keep the electrolyte at the correct level.
-  **CAUTION:** Machine damage and discharge across the tops of the batteries can occur if the batteries are filled above the bottom of the tube in each cell. Do not fill the batteries up to the bottom of the tube in each cell. Wipe any acid from the machine or the tops of the batteries. Never add acid to a battery after installation.
-  **CAUTION:** Tap water may contain contaminants that will damage batteries. Batteries must be re-filled with distilled water only.

2. Keep the tops of the batteries clean and dry. Keep the terminals and connectors clean. To clean the top of the batteries, use a damp cloth with a weak solution. To clean the terminals and connectors, use a terminal and connector cleaning tool. Do not allow ammonia or bicarbonate of soda to get into batteries.
3. Keep the batteries charged.

How to Charge the Batteries

-  **WARNING:** Charging the batteries in an area without adequate ventilation could result in an explosion. To prevent an explosion, charge the batteries only in an area with good ventilation.
-  **WARNING:** Lead acid batteries generate gases which could explode. Keep sparks and flames away from batteries. **NO SMOKING!**
-  **WARNING:** Failure to disconnect the AC plug from the wall receptacle before connecting or disconnecting the DC connector on the charger could result in an explosion. Always disconnect the AC plug from the wall receptacle before connecting or disconnecting the DC connector on the charger.

HOW TO PREPARE THE MACHINE FOR OPERATION

To charge the batteries, follow this procedure:

1. Put the charger on a flat surface. Make sure the vents on the side are at least two inches away from walls and other objects. Make sure there are no objects near the vents on the bottom of the charger.
2. Make sure the key switch is in the "OFF" position.
3. Disconnect the battery pack connector from the control housing connector. See figure 13, A.
4. Connect the DC connector on the charger to the battery pack connector. See figure 14.
5. Connect the charger to a properly grounded single phase (3-wire) wall receptacle having the voltage, frequency, and ampere capacity specified on the nameplate of the charger.

For more instruction on the use of the charger, read the instruction book supplied with the charger.

⚠ DANGER: Failure to read the operator's manual before operating this machine could result in injury to you or to other personnel, damage to the machine or to other property as well.

⚠ CAUTION: The antifreeze solution that is shipped in your machine will damage carpet. Flush the antifreeze solution from the system before using the machine.

Your new machine has been shipped with antifreeze solution in the machine's system. This antifreeze must be flushed out prior to using the machine the first time.

To flush the antifreeze solution follow this procedure:

1. Move machine to a non-carpeted area with a floor drain.
NOTE: Drive wheels must be lifted off the ground for this step.
2. Position the machine over the drain.
NOTE: Do not use water that is hotter than 140°F.
3. Add a minimum of five (5) gallons of clean water to the solution tank.

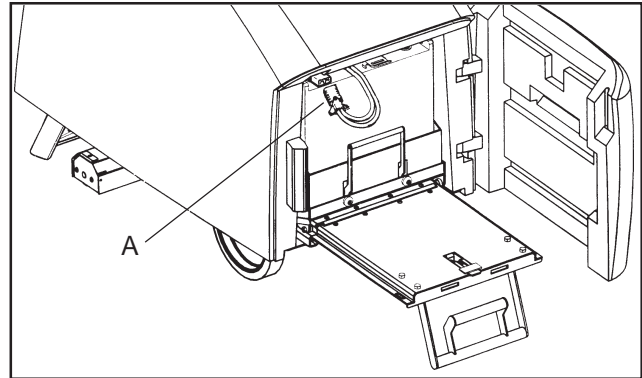

Figure 13

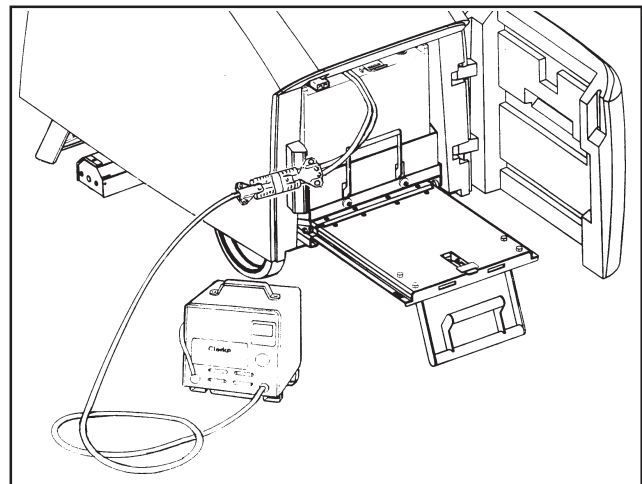

Figure 14

4. Turn the key switch to the "ON" position.
5. Press either of the traverse switches to activate spray.
6. Allow the solution to run through the machine over the floor drain until the solution tank is empty.

⚠ CAUTION: Cleaning solution in the machine and tools can leak onto the carpet and cause light spots or stains. Do not leave the extractor or other cleaning machines or tools on the carpet when not in use.

MACHINE OPERATING INSTRUCTIONS

⚠ DANGER: Failure to read the operator's manual before operating this machine could result in injury to you or to other personnel, damage to the machine or to other property as well.

⚠ CAUTION: Pump damage can occur if the pump is operated without water in the solution tank. Do not activate the pump if the solution tank is empty.

1. Put water and cleaning solution into the solution tank. Clarke recommends using Clarkare® Extractor Concentrate as a cleaning solution. For every gallon of water, add between two and ten ounces of Clarkare®. The amount of cleaning solution used depends on the condition of the carpet.

⚠ DANGER: Electrocution could occur if machine is connected to an electrical outlet that is not properly wired or grounded. Always use a 3-wire electrical system connected to electrical ground. For maximum protection, use a circuit that is protected by a ground fault circuit interrupter (GFCI). Consult your electrical contractor.

2. Make sure battery pack is plugged into machine.
3. Turn the key switch to the "ON" position.
4. Turn the traverse speed control to the desired position.
5. Turn pump pressure knob to desired setting.
6. Lower the recovery tool.
7. Apply pressure to either traverse switch on the control handle.
8. Adjust the brush to the proper carpet height setting.
9. Guiding the machine by the control handle, move across the floor in the forward direction.
10. Follow the path sequence.

NOTE: By properly planning the cleaning pattern, a minimum number of turns will need to be made. See figures 15a and 15b.

Low Voltage Condition:

NOTE: Verify battery condition under use. If batteries are discharged, pump and brush motor will not function. Vacuum and traverse continue to allow water recovery and ability to return to charging station.

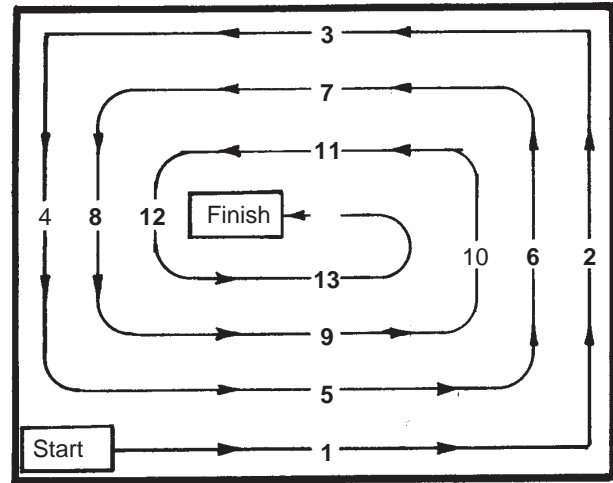

Figure 15a

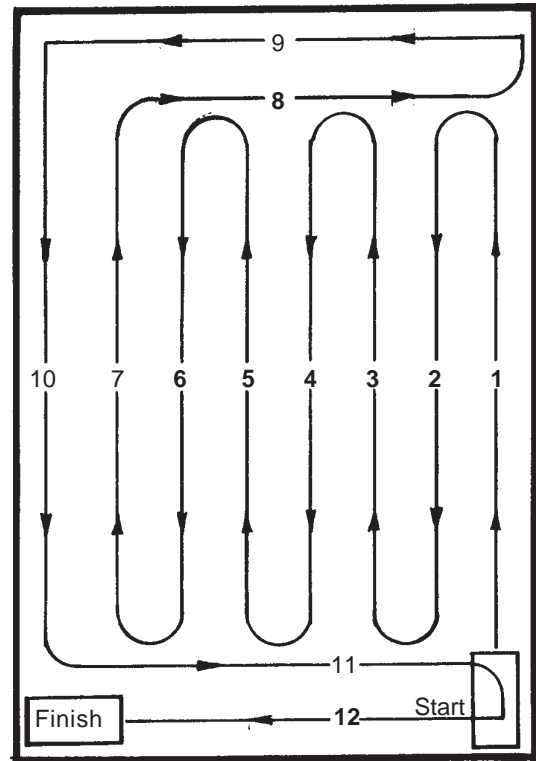

Figure 15b

MACHINE OPERATING INSTRUCTIONS

11. When cleaning in a corner, raise the brush, maneuver the machine as illustrated in figure 16. Lower the recovery tool and proceed with cleaning.

NOTE: If the extractor removes an excess amount of foam from the carpet, add a defoamer such as Clarkare® Defoamer Concentrate to the recovery tank. The amount needed will vary according to the amount of detergent already in the carpet.

To stop the machine follow these procedures:

1. Release pressure from the traverse switch on the control handle.
2. Raise the recovery tool handle to the "storage" position.
3. After a 10 second delay to allow all dirty solution to reach the recovery tank, the vacuum motors will automatically shut off.

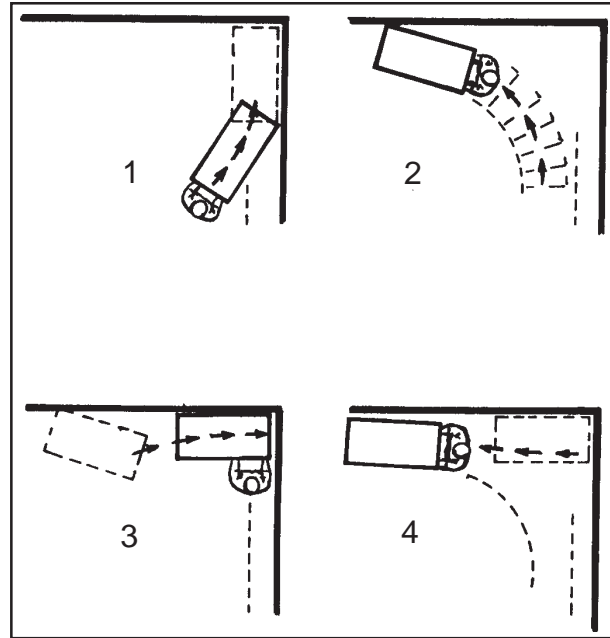

Figure 16

⚠ WARNING: Failure to turn all switches to the "OFF" position could result in injury or machine damage. Always position all of the switches into their "OFF" position when not in use.

⚠ WARNING: Machine can roll if left parked or unattended on an un-level surface and cause damage or injury. This machine is not equipped with a parking brake. Never leave the machine unattended. For added safety, always place a chock in front of and behind the drive wheel.

MACHINE OPERATING INSTRUCTIONS

After Each Use of the Machine

1. Turn main power switch to off position.
2. Drain and rinse out the recovery and the solution tank following this procedure:

For Recovery Tank

- a. Position the machine close to a floor drain or an appropriately sized bucket or container.
- b. Remove the hose from the fitting on the back of the machine.
- c. Put the end of the hose over a drain or bucket.
- d. Twist drain plug cap to release and drain tank.

For Solution Tank

- a. Remove clear hose from top connector.
- b. Position in appropriate container or floor drain.
- c. Drain tank.

NOTE: Draining process can be expedited by removing vac hose from recovery tool and inserting solution drain hose. Start vac motor after inserting hose. (See figure 17)

NOTE: Make sure to drain both the recovery tank and the solution tank.

3. Use a clean dry cloth to wipe out both tanks and the recovery tool, both inside and out.
4. Leave the tanks and drain hoses open to dry in the air.
5. Inspect and clean the filter screen between the solution tank and pump.

After Cleaning the Carpet

1. Do not walk or place heavy objects on the carpet for at least four hours or until the carpet is dry to the touch.
2. Vacuum right after the carpet is dry and vacuum at least once a week, or as often as needed.

⚠ CAUTION: You are responsible for Operator error. Clarke will not be held liable for damage to the carpet or for poor results because of the operator's errors.

3. To speed drying time of the carpet try a Clarke Direct Air carpet dryer.

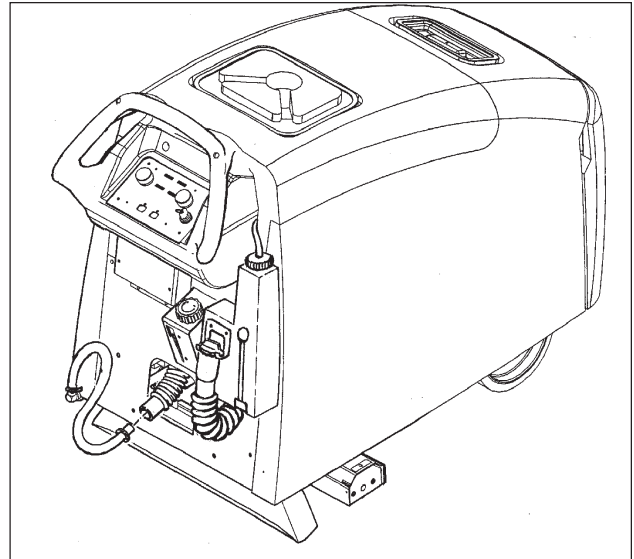



Figure 17

MAINTENANCE

 **WARNING:** Machine damage or injury could occur if maintenance and repairs are performed by unauthorized personnel. Maintenance and repairs must be done by authorized personnel only. Use only genuine Clarke parts.

NOTE: For maintenance of optional tools, read the manual that is supplied with the tools.

Always empty the solution and recovery tanks before performing any maintenance to the machine.

After Each Use of the Machine

1. To prevent damage to the valves and to the jets, flush one gallon of clean water through the solution system.
2. If the auxiliary tools have been used, be sure to flush them out with clean water.
3. Turn main power switch to off position.
4. Drain and rinse out the recovery tank.
5. Use a dry cloth to wipe the recovery tank, and the tools both inside and out.
6. Inspect and clean the filter screen in the inlet hose to the pump.

How to Prevent Freezing Temperature Damage

To prevent damage from freezing temperatures, follow this procedure:

1. Remove any solution remaining in the solution tank.
2. Make sure that the machine and the pump are completely dry.
3. Make sure the machine is at room temperature before using it.

Electrical

NOTE: For electrical repairs, return this machine to a Clarke authorized repair center.

MAINTENANCE

Recovery Tool (See figure 18)

The recovery tool is factory adjusted for optimum performance. If further adjustment is necessary, remove adjustment assembly. Loosen locknuts and lengthen or shorten dimension "A" as required.

Vacuum Motor

This machine has a vacuum motor that uses carbon brushes. The carbon brushes in the motor must be checked every three months, or every 500 hours of operation, whichever comes first.

Changing the Brush

The machine comes with one brush (PN 30167A):

1. **Black** - for everyday, routine carpet maintenance (Part No. 30167A). This brush is supplied with the machine.
2. **Black with white bristles on end** - for heavy-duty restoration carpet cleaning (Part No. 30166A). This brush must be purchased separately.

These brushes are reversible. After bristles are worn reverse the direction the brush was placed on the machine.

To change the brush follow this procedure:
(The brush can be changed or rotated by using the quick change brush door, see figure 19.)

1. Remove clamping knob.
2. Raise brush housing door approximately ¼ inch and pull out.
3. Swing door up to remove brush.
4. Remove the spacer and brush from the brush housing.
5. Place brush onto the shaft. Slide brush in and rotate until the pins catch. Slide spacer onto shaft.
6. Swing door down and slide onto shaft.
7. Replace clamping knob.

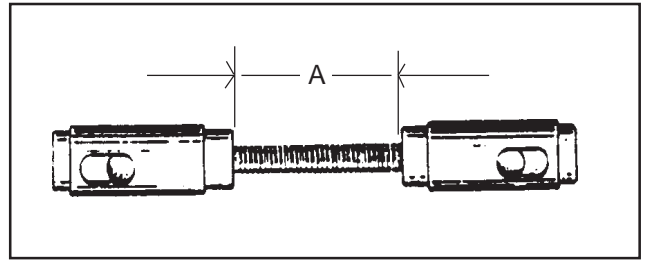

Figure 18

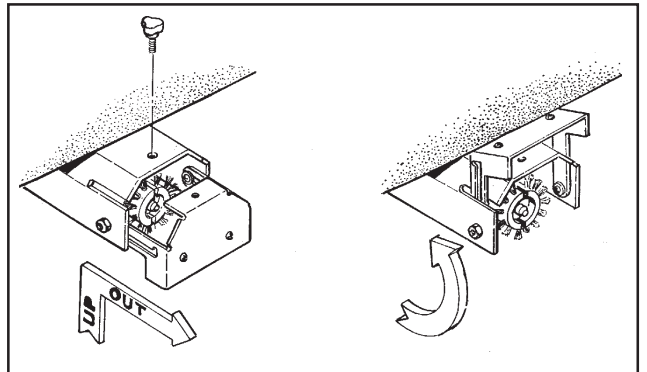

Figure 19

Nozzles

To remove the **nozzles** to clean or change nozzles, follow this procedure:

Recovery Tool

1. Grasp the nozzle cap assembly and twist counterclockwise to remove assembly from the spray bar.
2. Pull the nozzle out of the cap.
3. Clean or replace the nozzle.
4. Replace nozzle back into cap.
5. Twist nozzle cap assembly back onto the spray bar.

Brush Housing

1. Grasp spray bar and push towards brush motor to compress spring.
2. Swing out end of spray bar to remove it.
3. Pull nozzle assembly out to side of machine.
4. Firmly push nozzle in and turn 1/4 turn.
5. Pull nozzle out.
6. Clean and replace into nozzle assembly.
7. Replace nozzle assembly in brush housing.

Clarke®

IMAGE 26B

WASH & RINSE®

Section II

Parts and Service Manual

How to Correct Problems in the Machine

Problem	Cause	Action
The machine does not move.	The Power switch is off.	Turn on the "Power" switch.
	The traverse switch is defective.	Contact an authorized Clarke service person
There is no solution flow.	Solution control dial in wrong position.	Turn dial to position for more flow.
	The solution tank is empty.	Fill the solution tank.
	There is an obstruction in the solution hose or filter.	Remove the obstruction from the hose or filter.
	Solenoid is defective.	Contact an authorized Clarke Service person
	Pump is defective.	Contact an authorized Clarke Service person.
	Batteries are too low.	Charge unit.
The machine doesn't extract solution from the floor.	The recovery tank is full.	Drain the recovery tank.
	The recovery tool is not resting on the floor.	Lower and/or adjust the tool.
	Filter screen plugged	Clean screen and replace.
The cleaning is not even. service person.	The brush is worn.	Replace the brush.
	There is damage to the brush module or spray assembly.	Contact an authorized Clarke Service person.
	The solution level is low.	Fill the solution tank.
	Batteries are too low.	Recharge batteries.
Uneven or no spray from nozzles.	Dirty or plugged spray nozzles.	Clean the spray assembly or nozzles.
	Worn spray nozzles.	Replace spray assembly or nozzles.
Water leaks from the spray nozzles with the pump "OFF".	Debris in the check valve.	Contact an authorized Clarke service person.
	Defective check valve.	Contact an authorized Clarke service person.
There is no suction.	The vac motor is not running.	Turn vac motor switch on.
	Vacuum hose obstruction.	Remove the obstruction.
	Vac hose damaged.	Replace the hose.
	The dome gasket worn or damaged.	Replace the gasket.
	Motor brushes are worn.	Replace motor brushes.
	Loose motor connection.	Contact an authorized Clarke service person.
	Vac motor switch defective.	Contact an authorized Clarke service person.
Brush does not run or runs intermittently.	Batteries are too low.	Charge Batteries.

Clarke® Image 26B
Recovery Tank and Hose Assembly Drawing and Parts List 8/03

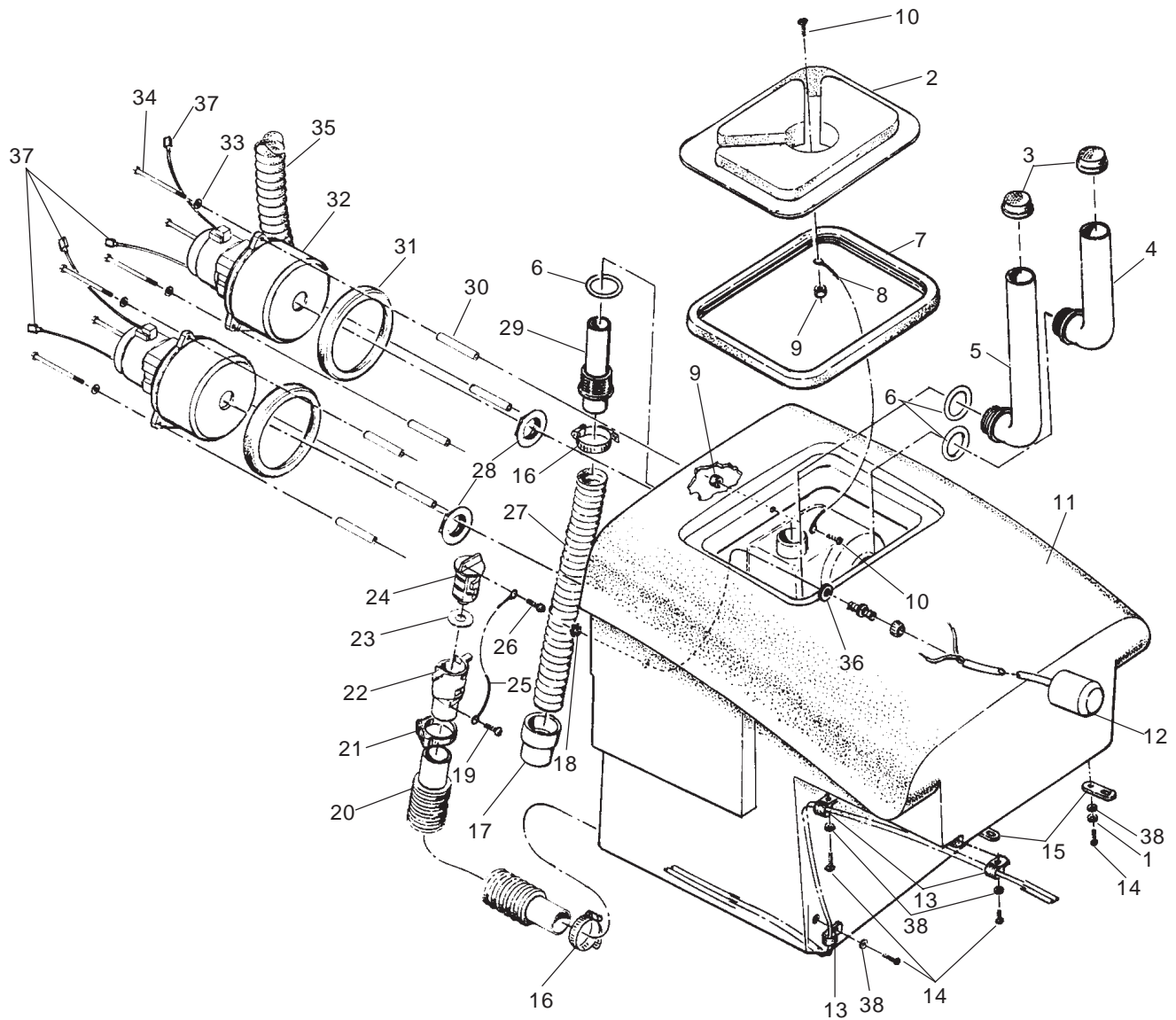

Ref	Part No.	Description	Qty
1	980657	Lock Washer	4
2	36204B	Lid, Recovery	1
3	58069A	Strainer, Recovery Tank	2
4	39339B	Standtube, Vac	1
5	39340B	Standtube, Vac	1
6	837304	O-Ring	3
7	34265A	Gasket, Recovery Lid	1
8	38020A	Strap	1
9	81110A	Nut, 10-24 ESNA	2
10	962666	Screw, 10-24 x 5/8 Pan SS	2
11	30183A	Tank, Recovery	1
12	47419A	Switch, Float	1
13	98465A	Clamp, Battery Cable	3
14	85806A	Screw, 1/4-20 x 1/2	7
15	65716A	Solution/Recovery Bracket	2
16	872010	Clamp, Hose	2
17	51863A	Cuff	1
18	82100A	Nut, Lock	1
19	962943	Screw, 8-18 x 1/2 PH	1

Ref	Part No.	Description	Qty
20	30415A	Hose, Drain	1
21	832002	Clamp, Drain Valve	1
22	839401	Valve, Drain	1
23	833407	Gasket, Drain	1
24	833901	Drain Valve Handle	1
25	52206A	Chain	1
26	962987	Screw	1
27	30011A	Hose, Shoe to Tank	1
28	920797	Nut	2
29	30010A	Adapter Asm., Vac	1
30	58533A	Spacer, Vac Motor	6
31	643418	Gasket, Vac Motor	2
32	45019A	Vac Motor	2
33	87026A	Washer, Flat 1/4	6
34	85728A	Screw, 1/4-20 x 4	6
35	30448A	Hose, Vac Exhaust	1
36	59877A	Washer, O-Ring	1
37	47905A	Terminal	4
38	980646	Washer	7

Clarke® Image 26B
Handle Assembly Drawing and Parts List 8/03

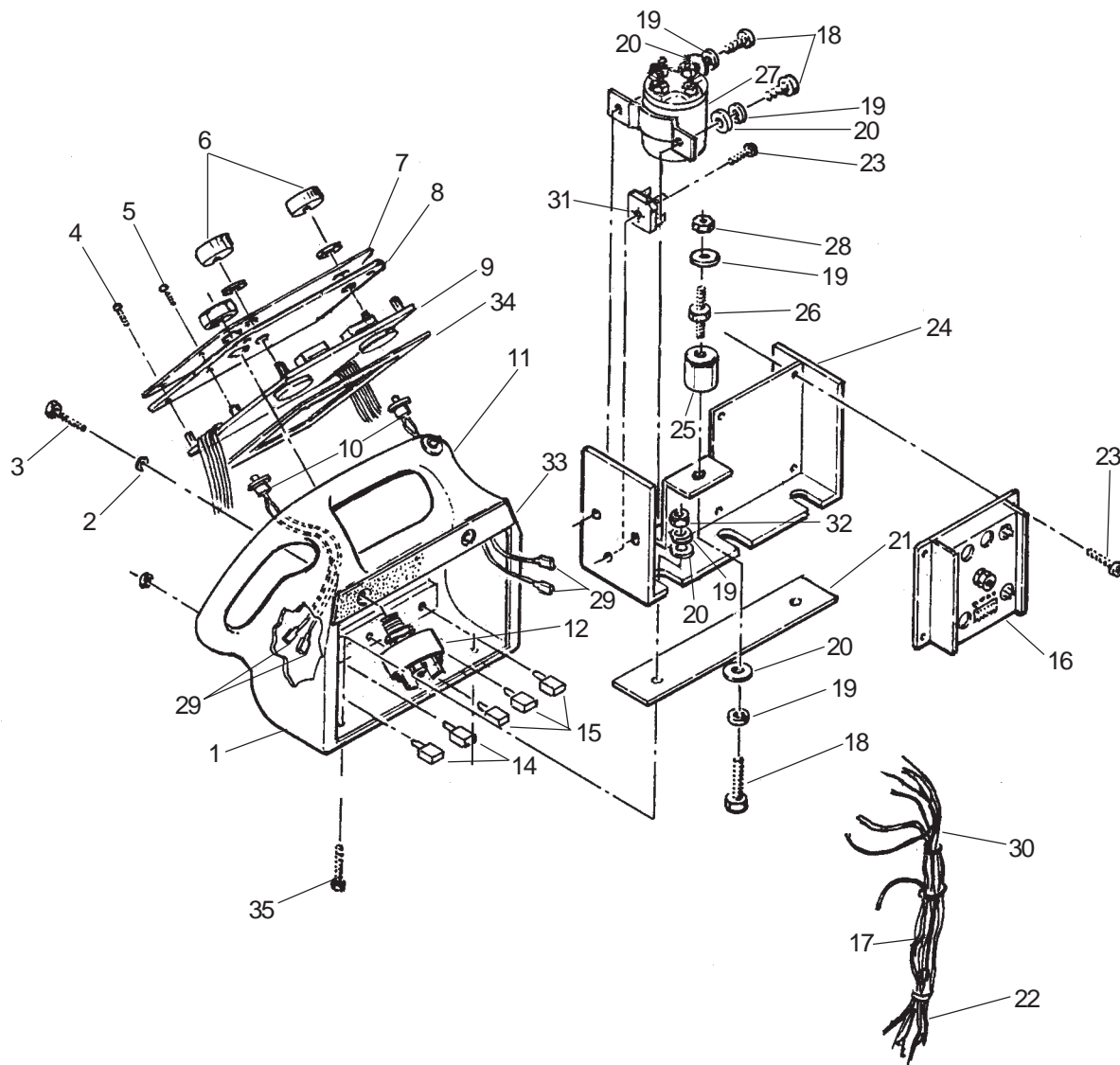

Ref	Part No.	Description	Qty
1	34813A	Handle	1
2	980645	Washer, 3/8 Flat	2
3	962522	Screw, 3/8 -16 x 2	2
4	962968	Screw, 10-24 x 1/2	4
5	85313C	Screw, 6-32 x 3/8	4
6	55502A	Knob	2
7	77368A	Label, Control Panel	1
8	66257A	Panel, Control	1
9	44309A	Module, Control	1
10	53077B	Switch, Forward	2
11	40158A	Switch, Reverse	1
12	47380A	Switch, Key	1
14	41438B	Circuit Breaker, 7A (br. motor)	2
15	41422B	Circuit Breaker, 25A (vac/tr mtr)	3
16	41161A	Control Motor, Quad	1
17	40190B	Harness, Wiring	1
18	962430	Screw, 1/4-20 x 1/2	3

Ref	Part No.	Description	Qty
19	980657	Washer, 1/4 Lock	4
20	980646	Washer, 1/4 Flat	5
21	64247A	Plate, Retaining	1
22	40006A	Harness, Wire	1
23	962350	Screw, 10-32 x 1/2	5
24	61687A	Weldment, Handle Cont	1
25	854849	Insulator	1
26	83302A	Stud, 1/4-20	1
27	41801A	Contactors 36V	1
28	920208	Nut	1
29	47905A	Terminal	6
30	40005B	Harness, Wire	1
31	912287	Rectifier	1
32	81102A	Nut, Nylock	2
33	30033A	Gasket, Handle	1
34	30032A	Gasket, Control Panel	1
35	Page 23	(see item #35)	2

Clarke® Image 26B
Rear Panel Assembly and Parts List 8/03

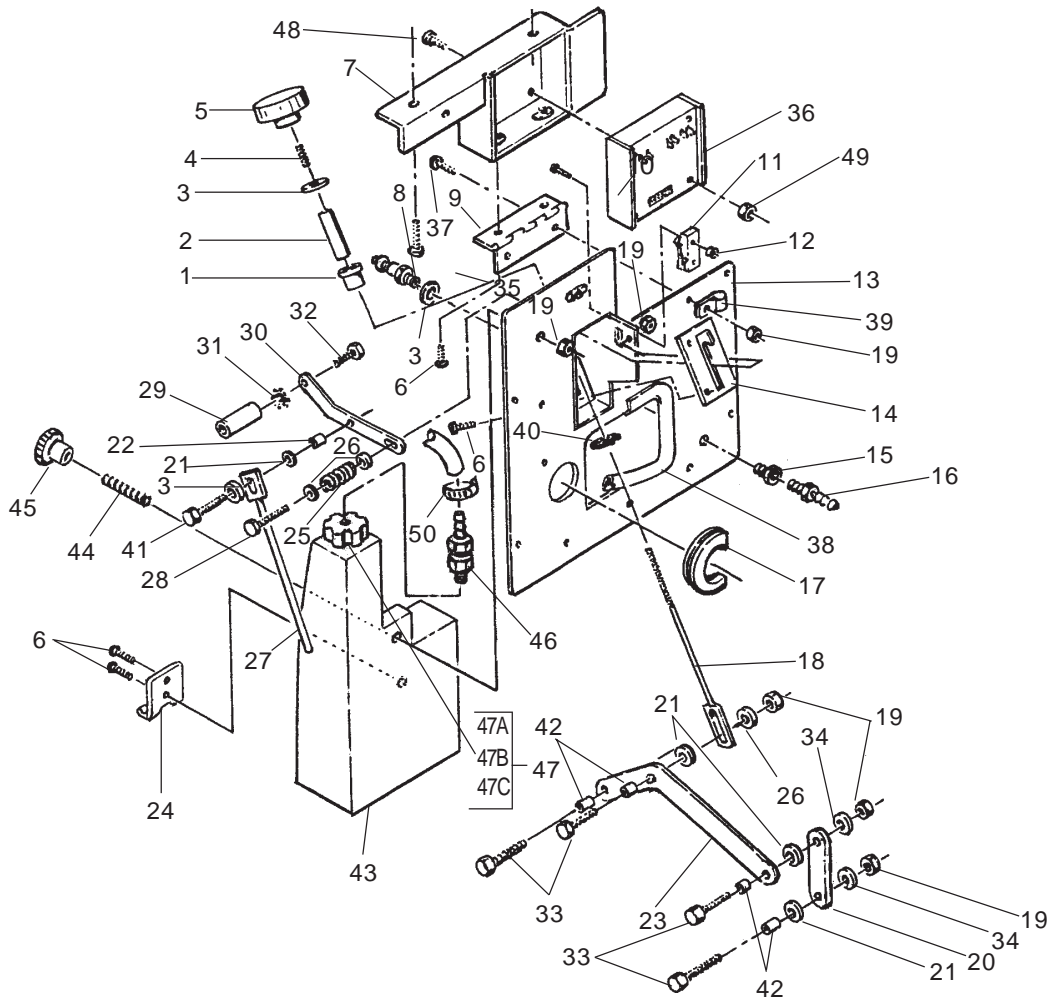

Ref	Part No.	Description	Qty	Ref	Part No.	Description	Qty
1	51535A	Bushing, 5/8 x 3/4	1	30	64906A	Handle, Recovery Tool Lift	1
2	61685A	Control, Brush Height	1	31	980666	Washer, Starlock 3/8	1
3	980645	Washer, Flat 3/8	3	32	85389A	Screw, 3/8 -16 x 5/8	1
4	86207A	Screw, Set 3/8 -16 x 1	1	33	85806A	Screw, 1/4-20 x 3/4	3
5	55537A	Knob, Brush Pressure	1	34	87026A	Washer, Flat 1/4	2
6	85395A	Screw, 1/4-20 x 1/2	12	35	85700A	Screw, 1/4 x 20 x 1	2
7	69196A	Top Rear Panel	1	36	41160B	Control, Motor	1
8	737140	Quick Disconnect	1	37	85390A	Screw, 1/4"	1
9	64521A	Hinge, Rear Panel	1	38	30021A	Trim, Frame	1
10	962980	Screw, 6-32 x 7/8	2	39	98465A	Clamp, Insulated	1
11	47374A	Switch, Straight Lever	1	40	857345	Snap Ring	1
12	920056	Nut, 6-32 ESNA	2	41	962430	Screw	1
13	69386A	Rear Panel	1	42	50249A	Spacer	4
14	68796A	Wear Plate	1	43	30089A	Tank, Chemical	1
15	697501	Reducer, 1/4NPT-1/8NPT	1	44	51209A	Pin, Chemical Jug	1
16	55167A	Hosebarb, 3/8 x 1/4	1	45	51210A	Knob, Chemical Tank	1
17	39102A	Trim, Frame	1	46	80134A	Fitting, Swivel	1
18	65448A	Brush Lift	1	47	10224A	Cap Assembly (incl. 47A-C)	1
19	81102A	Nut, 1/4-20 ESNA	6	47A	52333A	Hosebarb	1
20	65449A	Link, Brush Lift	1	47B	30090B	Cap, Chemical Jug	1
21	87618A	Washer, Flat 3/8 Nylon	5	47C	52419A	Tip, Lt. Blue Metering	2 oz/gal
22	608210	Spacer	1		52828A	Tip, Tan Metering	1 oz/gal
23	60467A	Arm, Brush Lift	1		52829A	Tip, Orange Metering	1.5 oz/gal
24	60052A	Retainer, Drain Valve	1		52831A	Tip, Pink Metering	3 oz/gal
25	438360	Spring, Adjustor	1	48	962968	Screw	4
26	980692	Washer, Flat 5/16 SS	3	49	81110A	Nut	4
27	65447A	Lift, Recovery Tool	1	50	722021	Hose Clamp	1
28	80028A	Bolt, Shoulder 5/16 x 1	1	N	77366A	Label	1
29	64490A	Handle	1	N	77367A	Label	1

Clarke® Image 26B
Solution Tank Assembly Drawing and Parts List 10/02

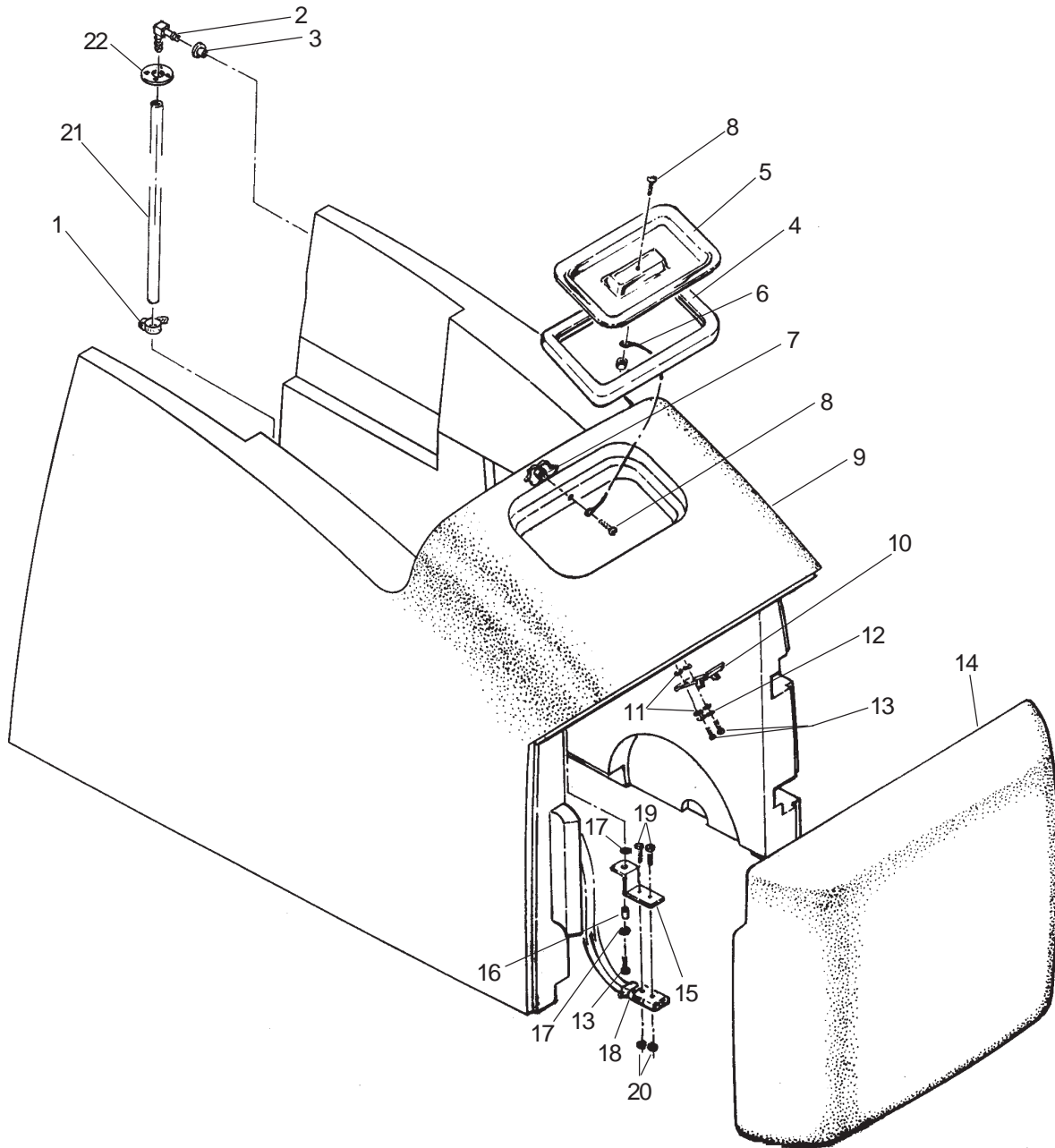

Ref	Part No.	Description	Qty
1	722030	Clamp, Hose #6	1
2	55189A	Elbow, 1/2	2
3	31242A	Bushing, 1/2 Fitting	2
4	34256A	Gasket	1
5	832322	Cover, Solution Tank	1
6	38020A	Chain	1
7	81110A	Nut, 10-24 ESNA	2
8	962666	Screw, 10-24 x 5/8 Pan SS	2
9	38820A	Tank, Solution	1
10	65506A	Latch, Bridge	1
11	980646	Washer, 1/4 Flat	4

Ref	Part No.	Description	Qty
12	980657	Washer, 1/4 Lock	2
13	85806A	Screws, 1/4-20 x 3/4	3
14	32416A	Cover, Front	1
15	61537A	Bracket, Bat Plug	1
16	608210	Spacer	1
17	87618A	Nylon Washer	2
18	41162A	Cable, Asm. Console	1
19	962212	Screw	2
20	920056	Nut	2
21	30463A	Hose	1
22	60218A	Plug, Drain	1

Clarke® Image 26B
Plumbing Detail Drawing and Parts List 3/04

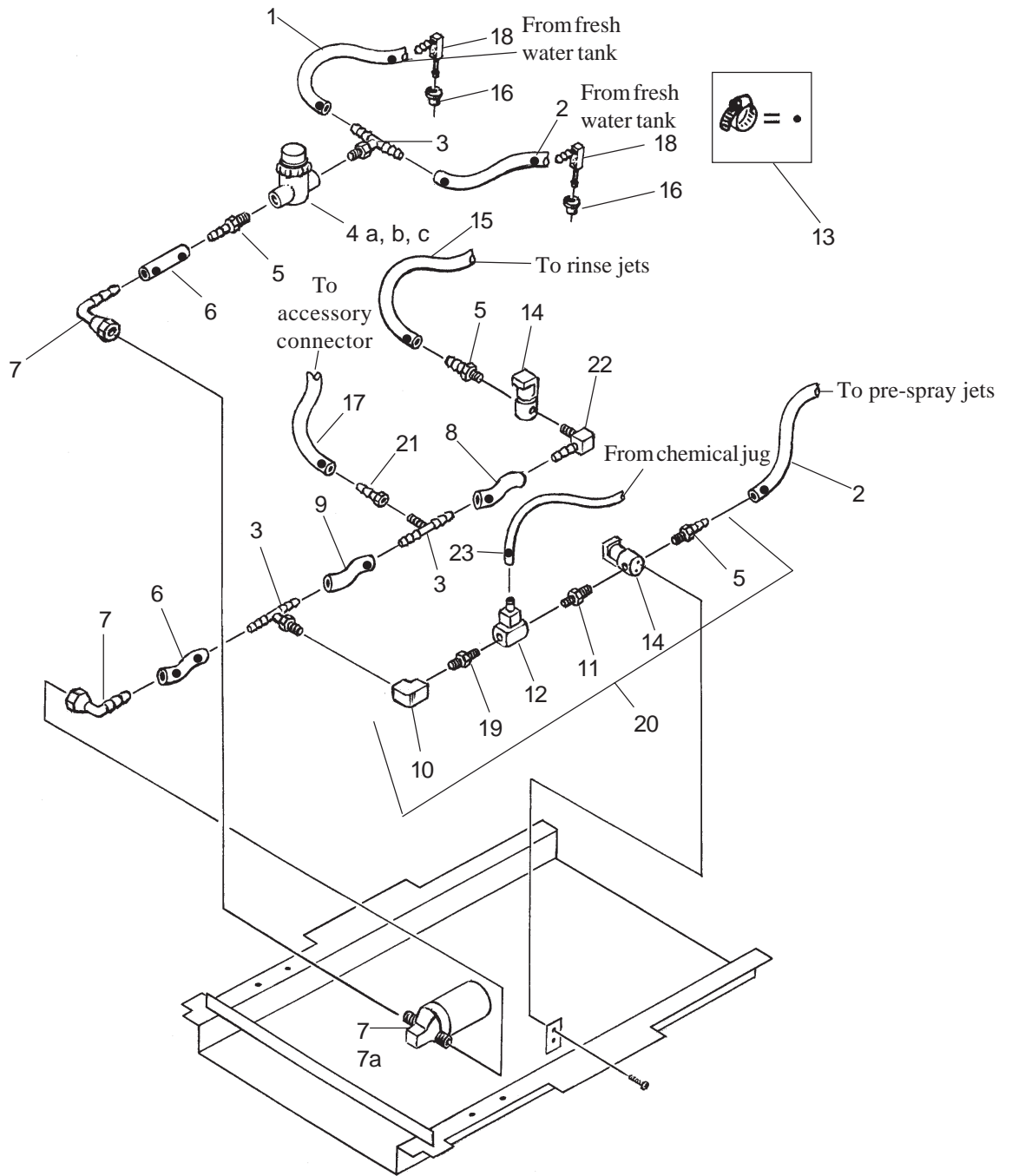

Ref	Part No.	Description	Qty
1	69404A	Hose 9"	1
2	35147A	Hose 3/8" 14"	2
3	59016A	Tee, Branch	3
4	53050A	Strainer, Bowl	1
4a	58061B	Strainer, Screen	1
4b	54369A	Gasket, viton	1
4c	90018A	Bowl, Filter	1
5	170030	Hosebarb 3/8"-1/4" NPT	3
6	694112	Hose	3
7	45950A	Pump	1
7a	52418A	Head Replacement, Pump	1
8	35148A	Hose	1
10	53639A	Elbow	1

Ref	Part No.	Description	Qty
11	851144	Adaptor	1
12	51207A	Injector	1
13	50248A	Clamp, Hose	11
14	59623A	Valve, Solution	2
15	30425A	Hose	1
16	51518A	Bushing, Hose	2
17	35168A	Hose	1
18	51526A	Elbow	2
19	697501	Reducer, 1/4 to 1/8	1
20	10229A	Injector Asm. (incl. 5, 10, 11, 12, 14 & 19)	1
21	55167A	Hosebarb	1
22	732870	Elbow	1
23	722021	Hose Clamp	1

Clarke® Image 26B
Frame Assembly Drawing and Parts List 6/04

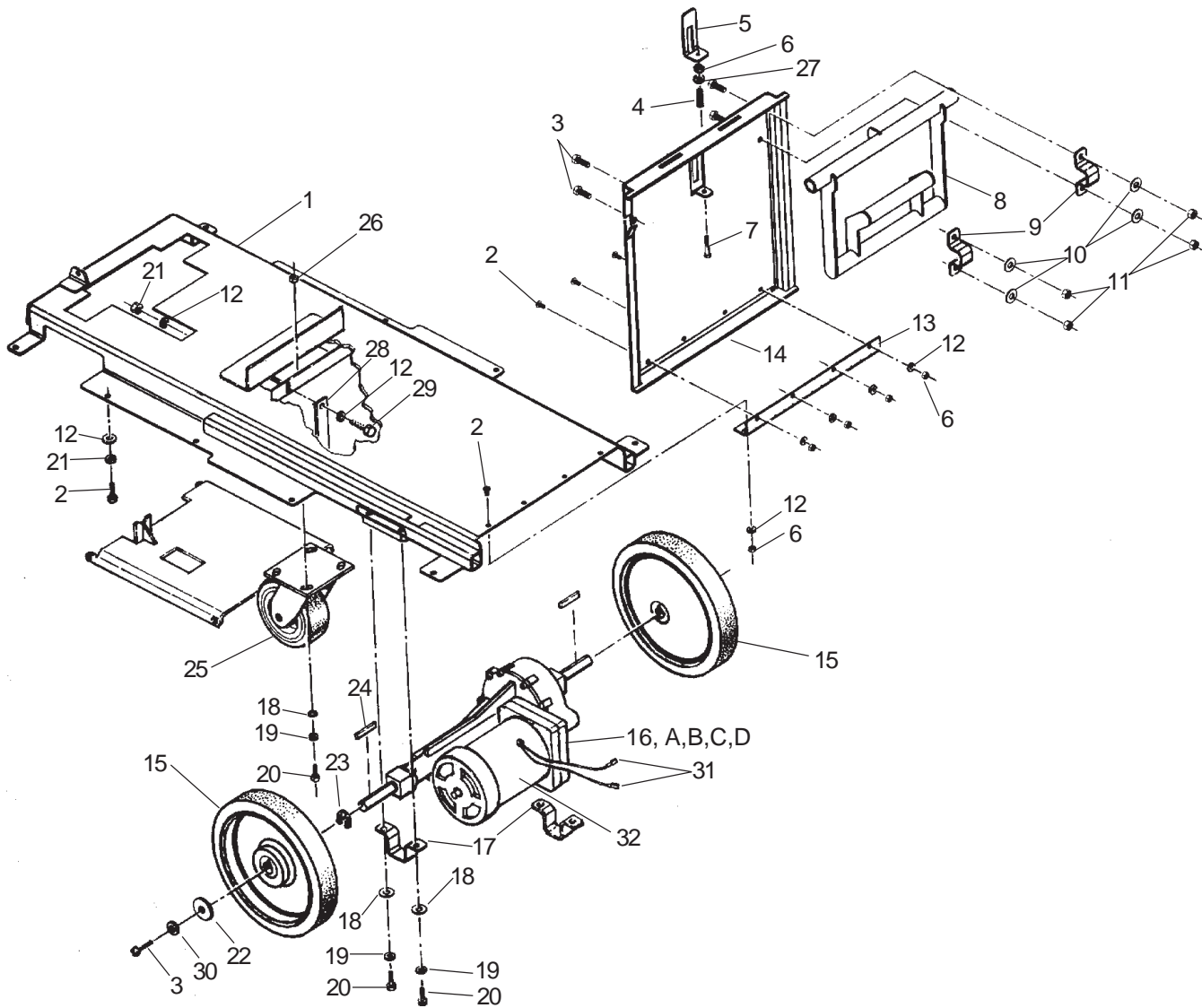

Ref	Part No.	Description	Qty
1	65979B	Frame	1
2	85806A	Screw, ¼-20x ¾	19
3	85811A	Screw, ⅝-18	6
4	58614A	Spring	1
5	65507A	Latch, Bridge	1
6	920208	Nut, ¼-20	9
7	85701A	Screw, ¼-20 x 1½	1
8	64907A	Handle	1
9	62450A	Clamp, Handle	2
10	980651	Washer, Flat ⅝	4
11	920110	Nut, ⅝-18	4
12	87026A	Washer, Flat ¼	20
13	55013A	Hinge	1
14	61539A	Bridge	1
15	69206A	Wheels	2
16	50008C	Transaxle	1
16A	52660A	Coupler, Transaxle	1
16B	50252A	Mount, Transaxle	1

Ref	Part No.	Description	Qty
16C	50251A	Motor, Brush	4
16D	50250B	Motor, Transaxle	1
17	62435A	Clamp, Transaxle	2
18	980645	Washer, Flat ⅜ SS	4
19	170883	Washer, Lock ⅜	4
20	85822A	Screw, ⅜-16 x 7/8	8
21	980657	Washer, Lock ¼	18
22	980205	Washer	2
23	57423A	Snap Ring	2
24	80507A	Key	2
25	899769	Casters	1
26	920260	Nut	4
27	980646	Washer	1
28	53087A	Strap, Static	1
29	81104A	Nut, ¼-20 SS	1
30	980652	Washer, Lock ⅝	2
31	47905A	Terminal	2
32	Page 30	Transaxle Parts	ref.

Clarke® Image 26B
Battery Tray Assembly Drawing and Parts List 10/02

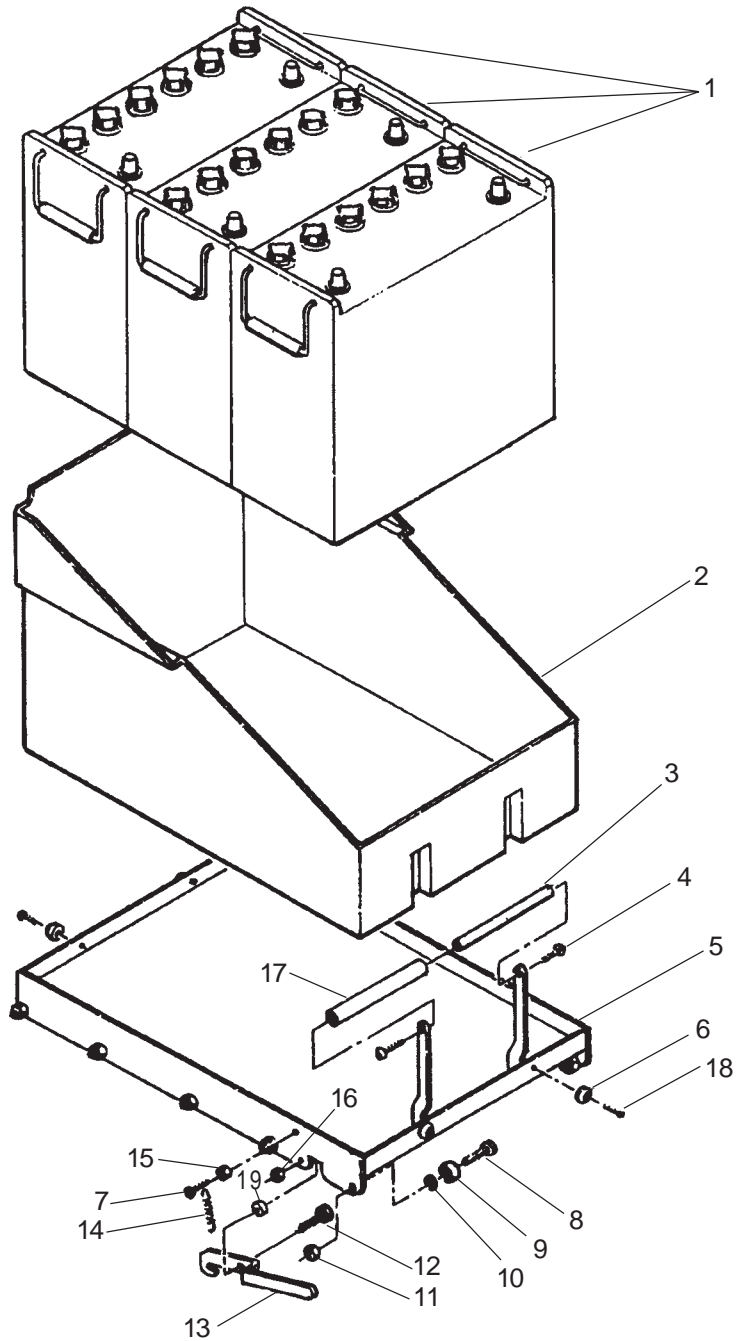

Ref	Part No.	Description	Qty
1	871334	Battery, 195 AH	3
2	39008B	Tray, Battery	1
3	54936A	Handle, Grip	1
4	85376A	Screw, 1/4-20 x 5/8	2
5	60001A	Battery Tray	1
6	51609A	Bumper	4
7	962350	Screw, 10-32 x 1/2	1
8	962986	Screw	10
9	902648	Bearing	10
10	980651	Washer	10
11	920160	Nut	10

Ref	Part No.	Description	Qty
12	962495	Screw	1
13	61434A	Arm, Battery Tray	1
14	668311	Spring	1
15	920224	Nut, Hex 10-32	1
16	81102A	Nut, 1/4-20 ESNA	1
17	34705A	Hose, Clear 6"	1
18	962929	Screw	4
19	61435A	Bushing	1
N	41217A	Cable, 16"	2
N	40532A	Cable Asm., Battery	1
NI	40506A	Charger, 36VDC	1

Clarke® Image 26B
Recovery Tool Assembly Drawing and Parts List 4/03
Form # 13005A

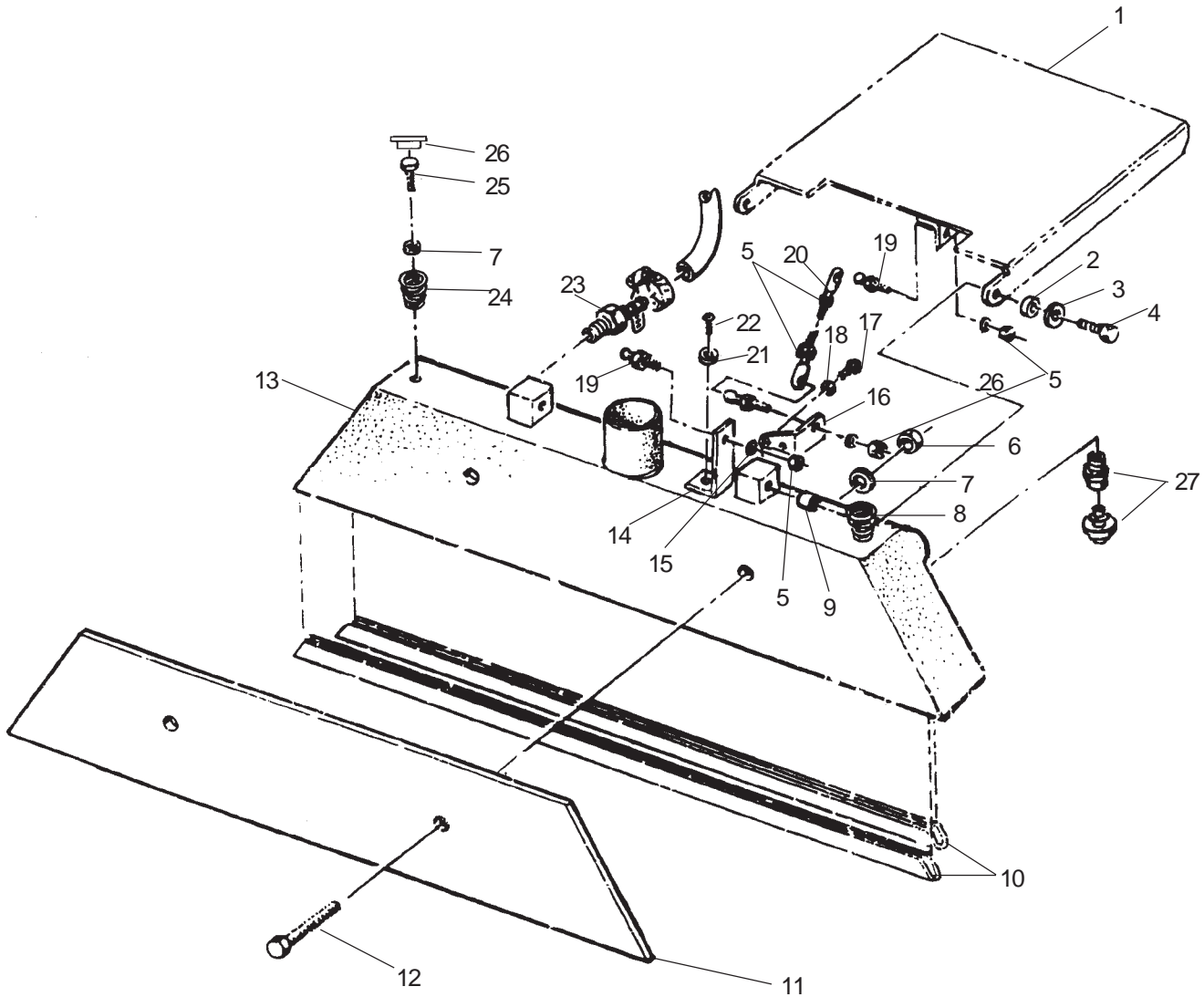

Ref	Part No.	Description	Qty
1	66816A	Recovery Lift	1
2	87618A	Washer, 3/8 Flat Nylon	2
3	980646	Washer, Flat 1/4	2
4	85806A	Screw, 1/4-20 x .75	2
5	81306A	Nut, Hex 5/16-24	5
6	920110	Nut, 5/16 ESNA	2
7	980651	Washer, Flat 5/16	4
8	58612A	Spring	1
9	608210	Spacer	2
10	67619A	Shoe, Recovery Tool	2
11	68808A	Weight, Recovery Tool	1
12	85615A	Screw, 5/16 -18 x 1 1/4	2
13	27201A	Shoe, Recovery	1
14	61541A	Bracket, Recovery Lift	1
15	980652	Lockwasher	3

Ref	Part No.	Description	Qty
16	65980A	Mount, Ball Joint	1
17	962798	Screw, 10-24 x 1/2 SS	2
18	980982	Washer, Flat #10	2
19	50546A	Ball-Joint	3
20	67164A	Rod, Recovery Tool Adj.	1
21	170883	Washer, Lock 3/8	1
22	962288	Screw, 3/8-16 x 1	1
23	170030	Hosebarb, 3/8-1/4 NPT	1
24	50240A	Spring	1
25	85395A	Screw, 1/4-20 x .50	2
26	30517A	Bushing	2
27	51320A	Nozzle, Rinse	4
27a	52549A	Nozzle, Rinse Plastic	4

*Optional Accessory

Clarke® Image 26B
Brush Assembly Drawing and Parts List 8/04

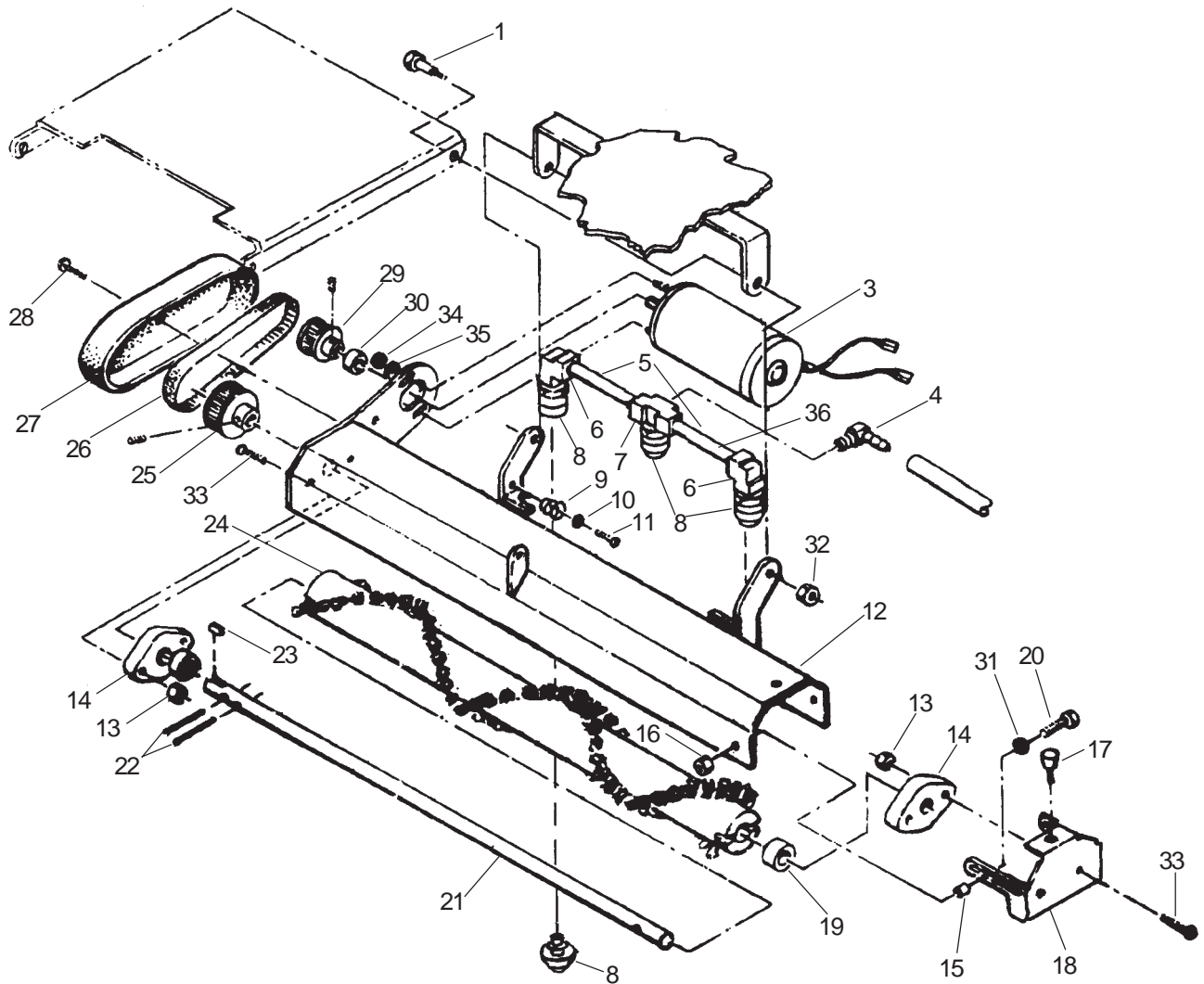

Ref	Part No.	Description	Qty
1	80041A	Bolt, Shoulder	2
3	44310A	Motor, Brush	1
3a	40832A	Brush, Carbon	2
4	732870	Elbow, 3/8	1
5	56365A	Nipple, Brass 4"	2
6	53639A	Elbow, Brass 1/4 NPT	2
7	51369A	Tee, Brass 1/4 NPT	1
8	51370A	Nozzle, Pre-Spray	3
8a	52550A	Nozzle, Pre-Spray Plastic	3
9	53426A	Spring	1
10	980982	Washer, Flat #10	1
11	85393A	Screw, 10-32 x 1/4	1
12	61542B	Brush Housing	1
13	81102A	Nut, 1/4-20 ESNA	4
14	53399A	Bearing Asm.	2
15	58548A	Spacer, Brush Door	2
16	81109A	Nut, 8-32 ESNA	2
17	55518A	Knob, Clamping	1
18	60089A	Door, Brush End	1

Ref	Part No.	Description	Qty
19	38708A	Spacer, Brush End	1
20	962027	Screw, 8-32 x 5/8	2
21	67481A	Shaft, Brush	1
22	50436A	Pin, Brush Drive	2
23	915082	Key	1
24	30167A	Brush, Maintenance	1
24a	30166A	Brush, Restoration	1
25	57247A	Pulley, Brush	1
26	50928A	Belt	1
27	30029A	Cover, Belt	1
28	85395A	Screw, 1/4-20 x .50	2
29	57268A	Pulley, Motor	1
30	58517A	Spacer, Motor	1
31	980646	Washer, Flat	2
32	920110	Nut	2
33	85390A	Screw, 1/4-20 x 1 1/4	4
34	920208	Nut, Hex 1/4-20	2
35	980614	Washer, Lock	2
36	10220A	Bar Asm., Pre-Spray (incl. 4, 5, 6, 7 & 8)	1

**Clarke® Image 26B
Transaxle Parts List 4/03**

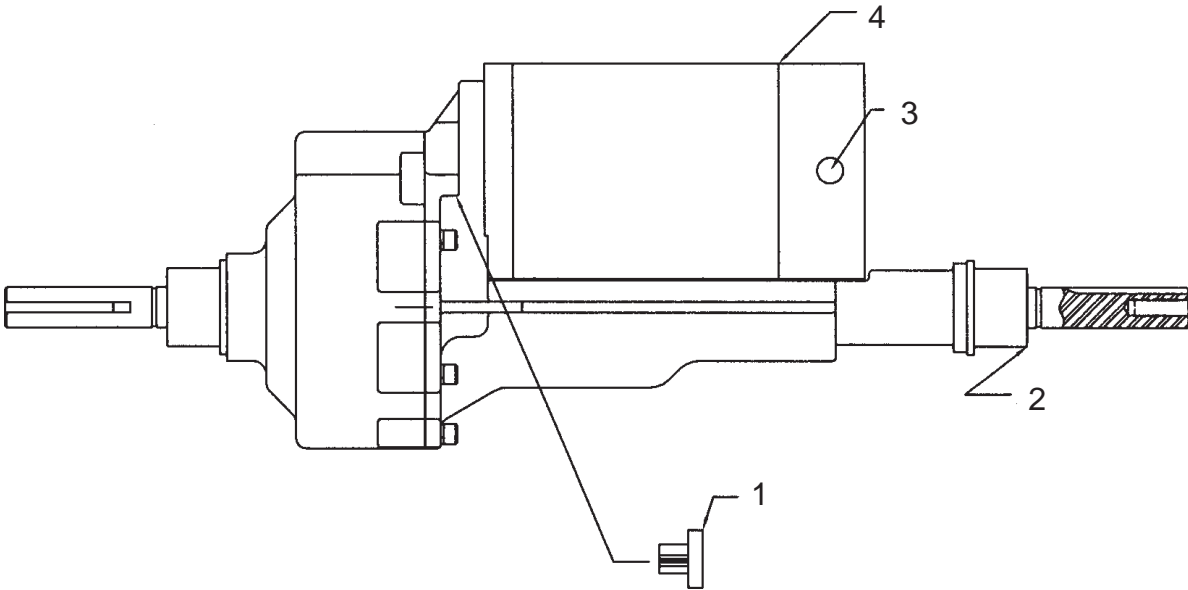

	50008C	50008B		
Ref #	Part No.		Description	Qty
1	50983A	52660A	Coupler, Transaxle	1
2	51056A	50252A	Mount, Transaxle	1
3	40628A	50251A	Brush, Carbon	1
4	40627A	50250B	Motor, Transaxle	1

Clarke® Image 26B
Vac Motor Assembly #45019A 10/02

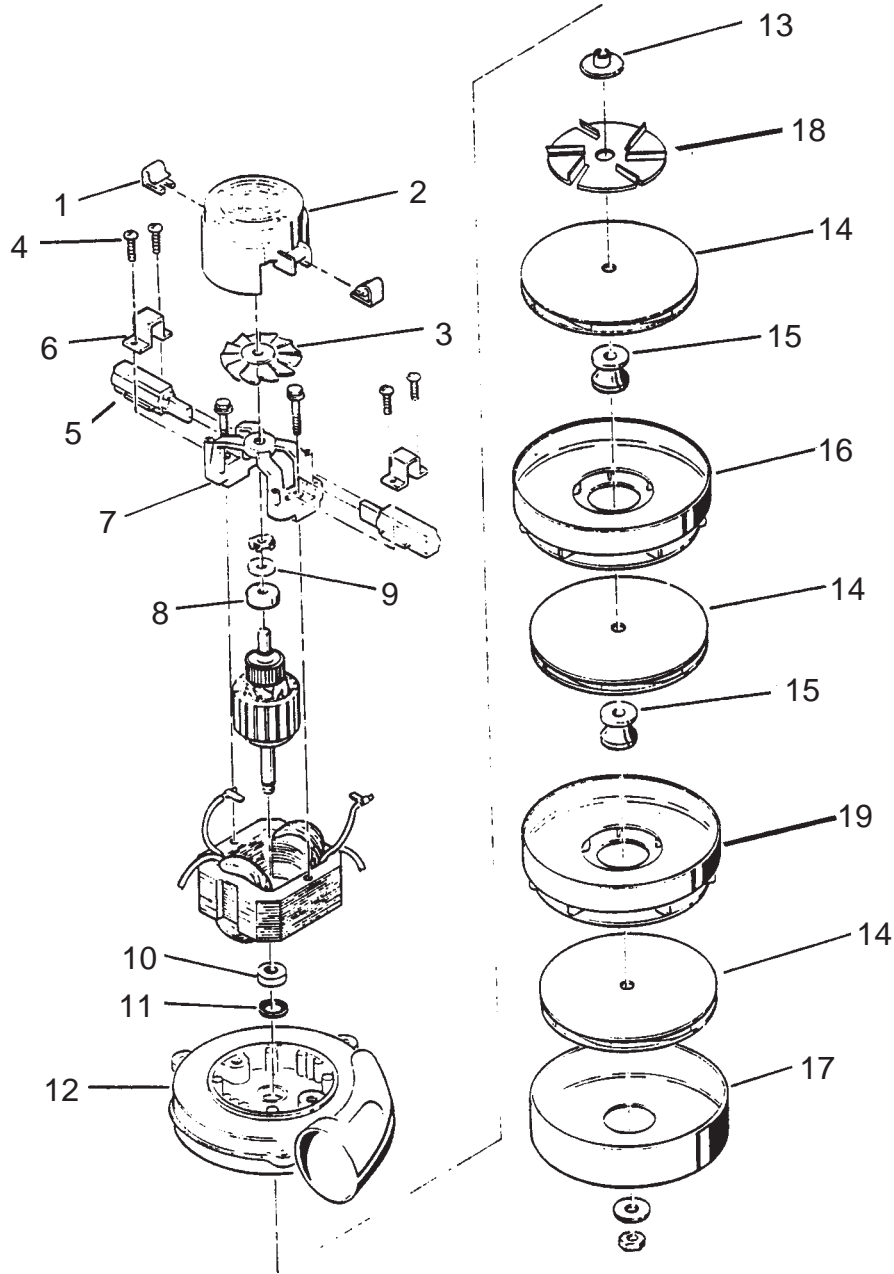

Ref #	Part No.	Description	Qty
1	51913A	Clip (optional)	2
2	54809A	Housing	1
3	53905A	Fan	1
4	85303A	Screw - 8-32 x 3/8	4
5	40830A	Carbon Brushes	2
6	51914A	Clamp	2
7	50618A	Bracket	1
8	53100A	Disc	1
9	902679	Bearing - Ball	1
10	902648	Bearing - ball, radial	1

Ref #	Part No.	Description	Qty
11	59803A	Washer - neoprene	1
12	50610A	Bracket and shell	1
13	58501A	Spacer	1
14	53914A	Fan - Rotating	3
15	658201	Spacer	2
16	53908A	Fan - Stationary	1
17	658506	Shell	1
18	53995A	Fan, Air Seal	1
19	53996A	Fan, Stationary	1

Clarke® Image 26B
36 Volt Battery Charger (40506A, 40507A, 40505A) 10/02

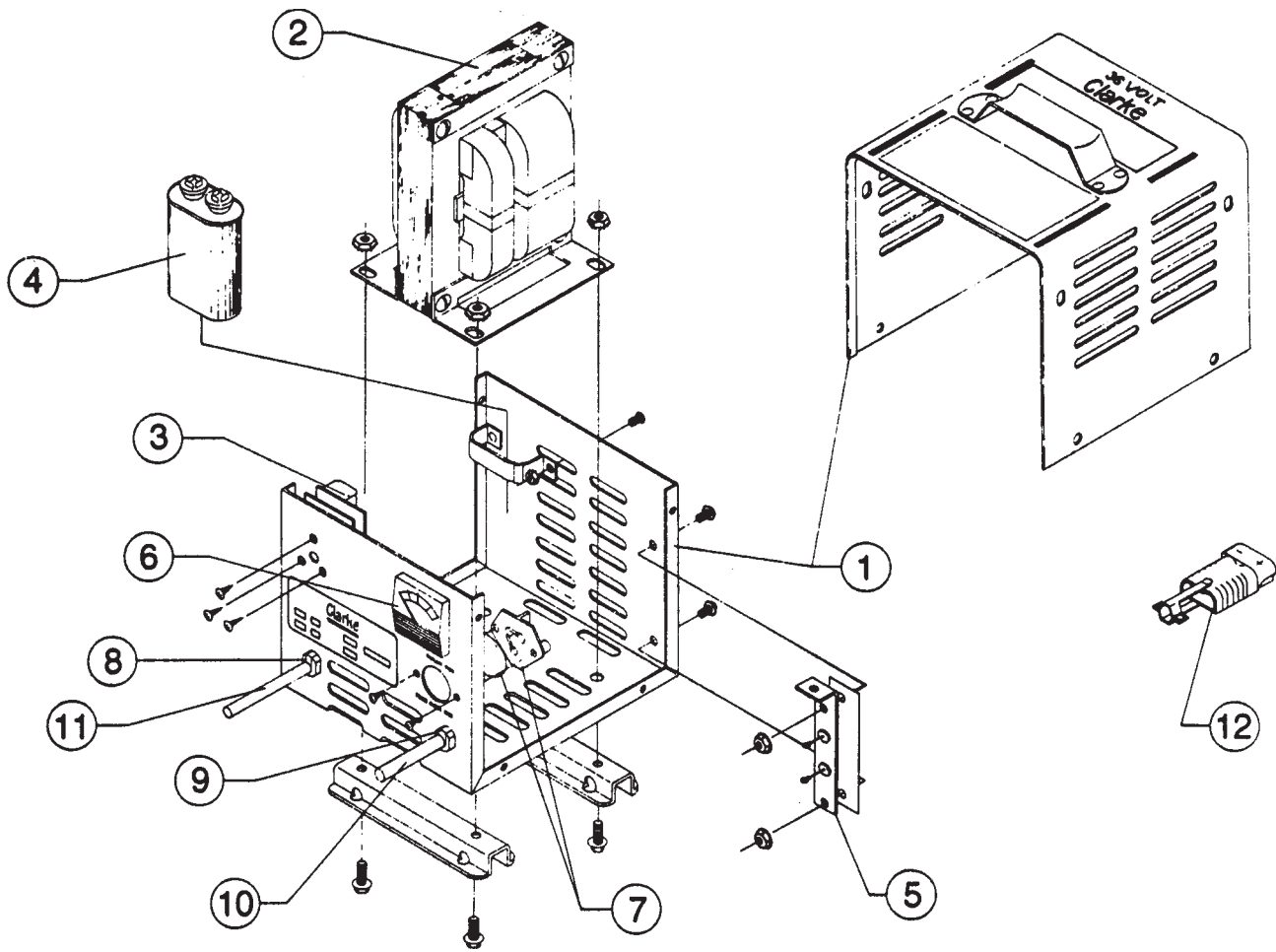

WARNING: All electrical repairs must be performed by qualified personnel only.

PARTS LIST FOR BATTERY CHARGERS

40506A - 36 Volt D.C., 25A, 115 Volt A.C., 60 Hz
 40505A - 36 Volt D.C., 25A, 230 Volt A.C., 50 Hz
 40507A - 36 Volt D.C., 25A, 230 Volt A.C., 60 Hz

Ref #	Description	Charger Model Number		
		40506A Part #	40507A Part #	40505A Part #
1	Charger Case	42503A	42504A	51959A
2	Transformer	48400A	48412A	48401A
3	Electronic Timer Kit	41102A	41103A	41103A
4	Capacitor, 6 Mfd., 660 V.A.C.	912132	912132	912132
5	Heat Sink Assembly	912212	912212	912212
6	Ammeter	40200A	40200A	40200A
7	Fuse Assembly	912382	912382	912382
8	Strain Relief, A.C. Cord	837525	837525	837525
9	Strain Relief, D.C. Cord	747553	747553	747553
10	D.C. Cord Assembly	51973A	51973A	51973A
11	A.C. Cord Assembly	51974A	908947	908947
12	D.C. Plug	911185	911185	911185
	D.C. Plug Lock Key	795020	795020	795020

Clarke® Image 26B
Battery Charger (40512B & 40506B) Drawing and Parts List 5/06

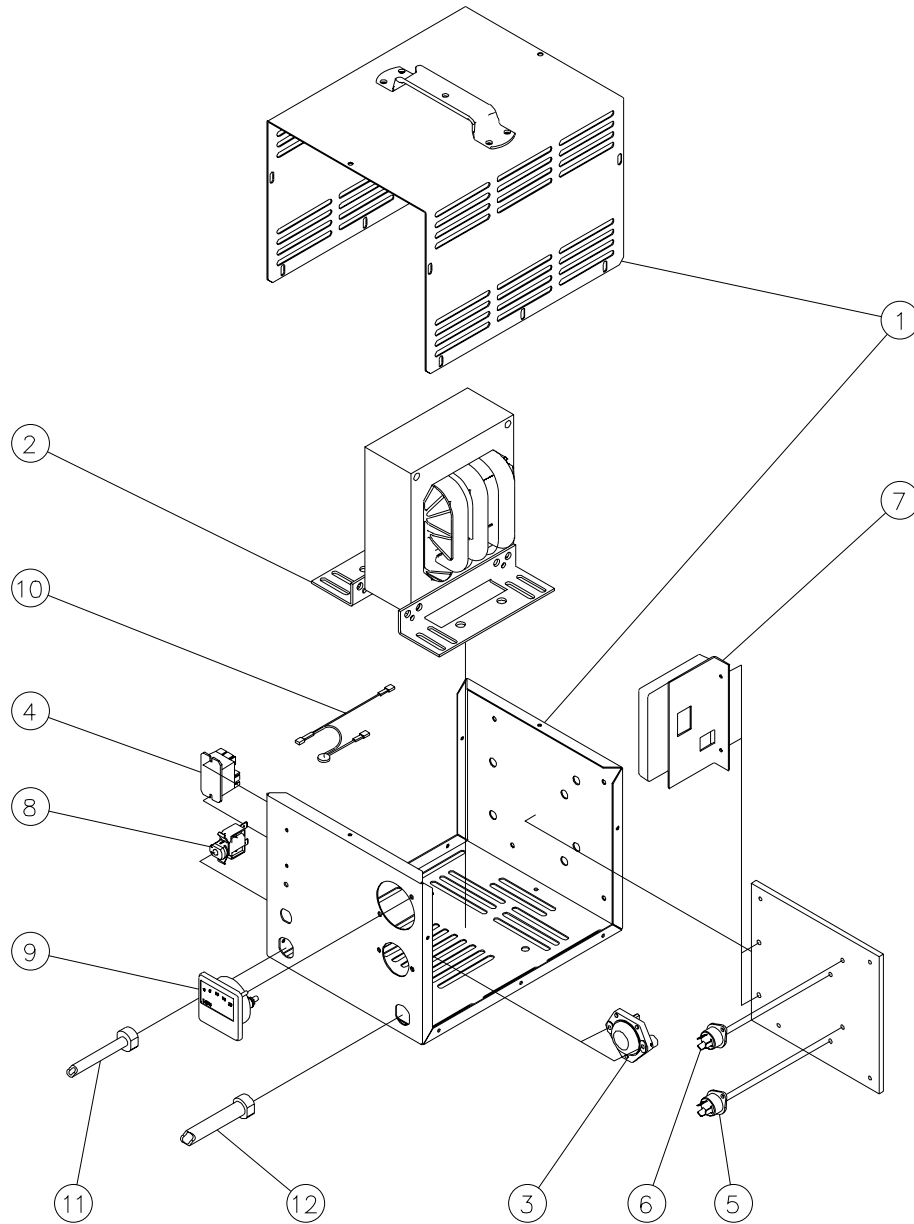

WARNING: All electrical repairs must be performed by qualified personnel only.

REF NO.	DESCRIPTION	40512B 24V 25A	40506B 36V 25A
1	CASE ASSEMBLY		
2	TRANSFORMER ASSEMBLY		
3	FUSE ASSEMBLY	912382	912382
4	D.C. RELAY		
5	SCR ASSEMBLY, BLUE & BROWN WIRES		
6	SCR ASSEMBLY, VIOLET & WHITE WIRES	11085A	11086A
7	ELECTRONIC CONTROLLER ASSEMBLY		
8	A.C. CIRCUIT BREAKER		
9	AMMETER		
10	A.C. SURGE PROTECTION		
11	A.C. CORDSET, 5-15P PLUG AND BUSHING		
12	D.C. CORDSET, SB50 GRAY PLUG W/ KEY		

Clarke® Image 26B
Available Accessories 8/03

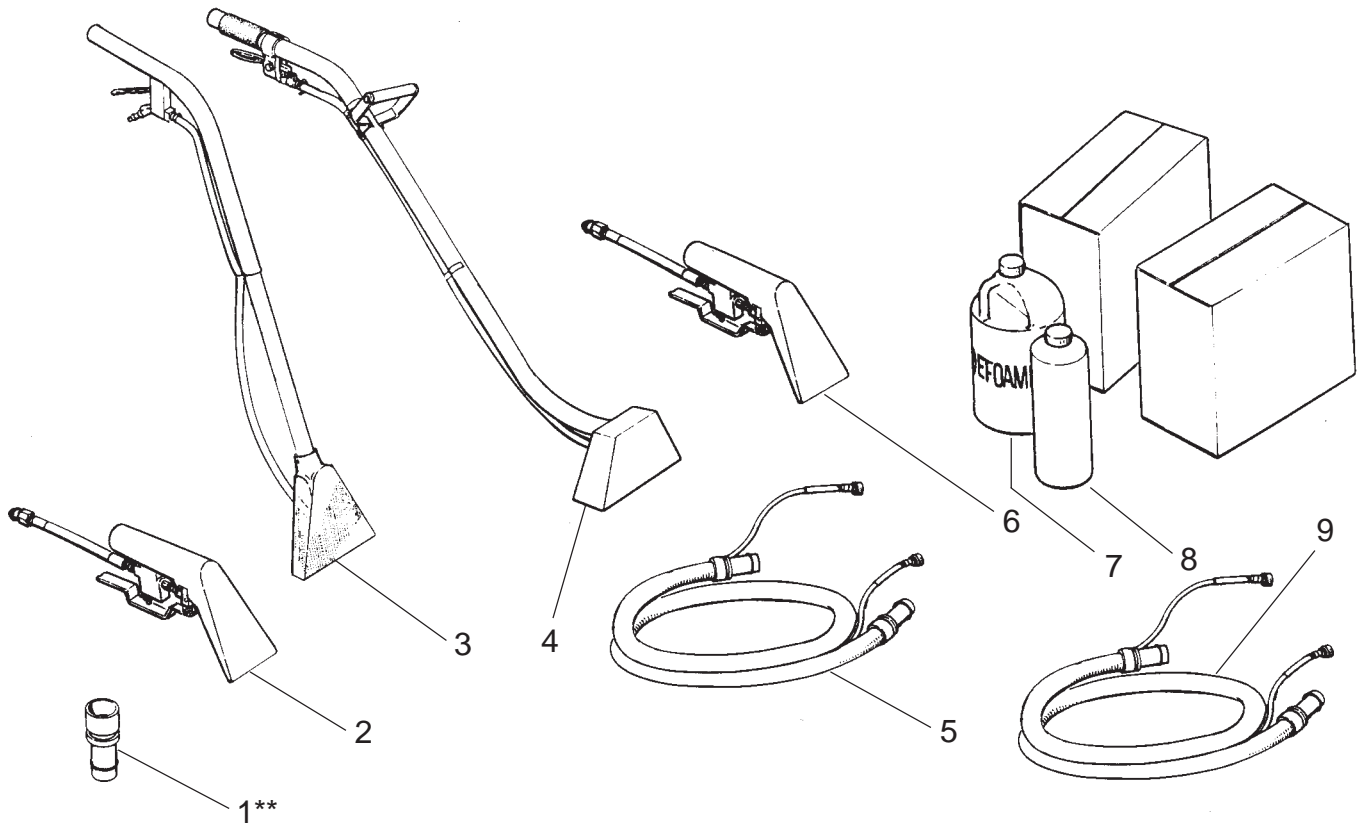

Ref	Part No.	Description	Qty
1	30108A	Adaptor, 2" to 1½"	1
2	59231A	RM-4P Tool Assembly	1
3	59230A	RM-8P Tool Assembly	1
4	59229A	RM-12M Tool Assembly	1
5	59232A	Hide-A- Hose 10'	1
6	59228A	RM-4M Tool Assembly	1
7	398426	Defoamer	*1 case
8	398425	Extractor, Concentrate	*1 case
9	55183A	Hide-A-Hose 20'	1
NI	55173A	4" Tool & Hose Assembly	1
NI	04130C	Deluxe Carpet Dryer	1

* 12, 1 quart bottles

**Required to use any accessory

Clarke® Image 26B Wiring Schematic 10/02

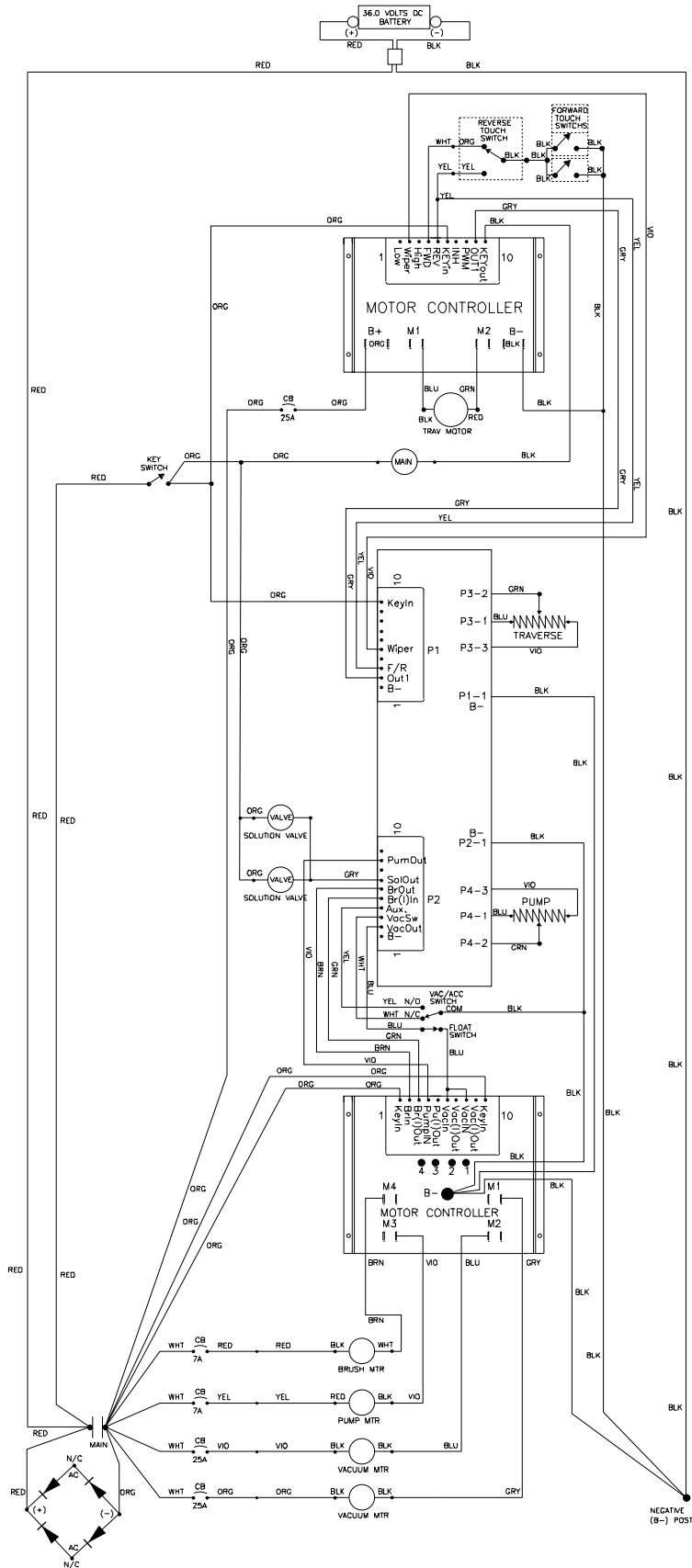

Clarke® Image 26B Connection Diagram 10/02

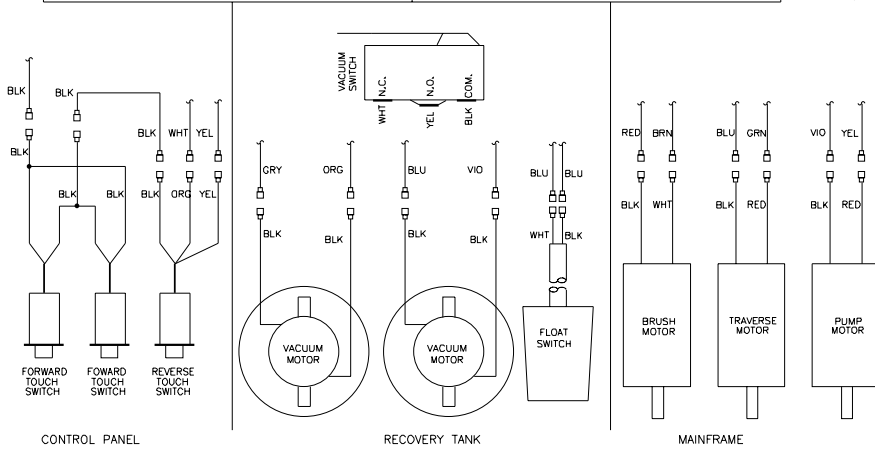
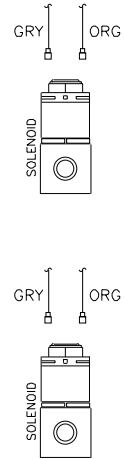
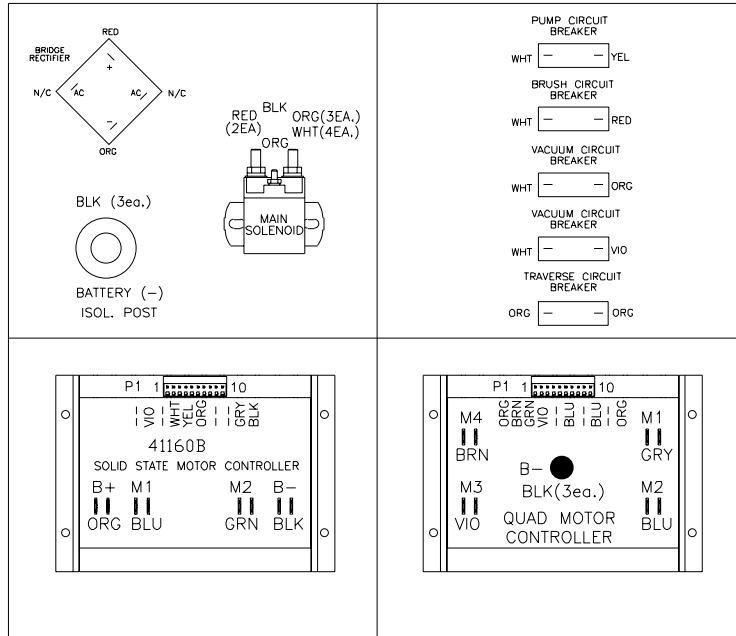
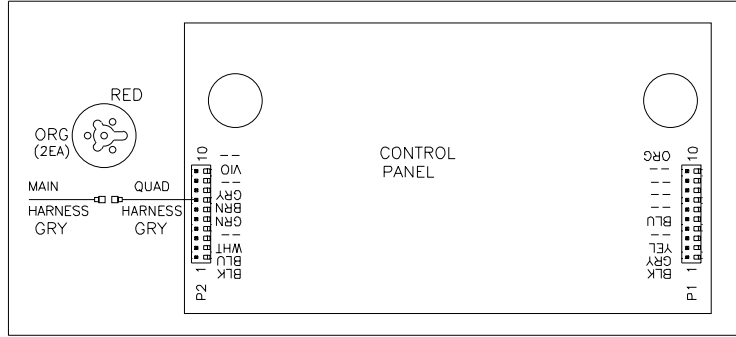

Clarke® Image 26B
Flow Diagram 10/02

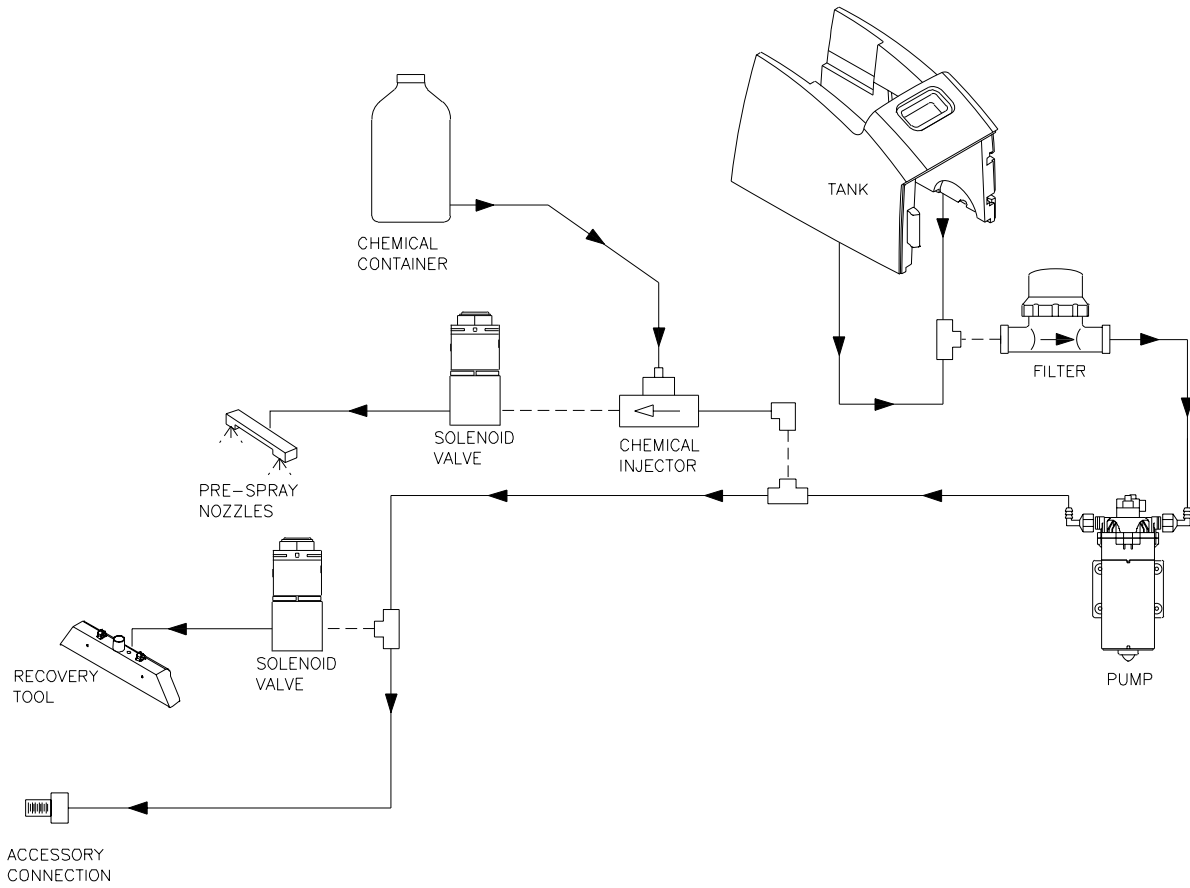

CLARKE PRODUCT SUPPORT BRANCHES

U. S. A. Locations

PRODUCTION FACILITIES

Clarke®, Springdale, Arkansas
2100 Highway 265
Springdale, Arkansas 72764
(479) 750-1000
Customer Service - 1-800-253-0367
Technical Service - 1-800-356-7274

American Lincoln®, Bowling Green, Ohio 43402
1100 Haskins Road

SERVICE FACILITIES

Clarke®, Elk Grove, Illinois 60007
2280 Elmhurst Road
(847) 956-7900

Clarke®, Denver, Colorado 80204
1955 West 13th Ave.
(303) 623-4367

Clarke®, Houston, Texas 77040
7215 North Gessner Road
713-937-7717

SERVICE AND SALES FACILITY

American Lincoln® / Clarke, Madison Heights,
Michigan 48071-0158
29815 John R.
(810) 544-6300

American Lincoln® / Clarke, Marietta, Georgia 30066
1455 Canton Road
(770) 973-5225

Clarke®

Clarke American Sanders

A.L. Cook

Customer Service Headquarters and Factory
2100 Highway 265
Springdale, Arkansas 72764
(479) 750-1000

Technical Service
1-800-356-7274

European Locations

PRODUCTION FACILITIES

ALTO Danmark A/S, Aalborg
Blytaekervej 2
DK-9000 Aalborg
+45 72 18 21 00

ALTO Danmark A/S, Hadsund
Industri kvarteret
DK-9560 Hadsund
+45 72 18 21 00

SALES SUBSIDIARIES

ALTO US - Canada, Ontario (Canada)
4080 B Sladeview Crescent Unit 1
Mississauga, Ontario L5L 5Y5
(905) 569 0266

ALTO Overseas Inc., Sydney (Australia)
1B/8 Resolution Drive
Caringbah NSW 2229
+61 2 9524 6122

ALTO Cleaning Systems Asia Pte Ltd., Singapore
No. 17 Link Road
Singapore 619034
+65 268 1006

ALTO Deutschland GmbH, Bellenberg (Germany)
Guido-Oberdorfer-Straße 2-8
89287 Bellenberg
+49 0180 5 37 37 37

ALTO Cleaning Systems (UK) Ltd., Penrith
Gilwilly Industrial Estate
Penrith
Cumbria CA11 9BN
+44 1768 868 995

ALTO France S.A. Strasbourg
B.P. 44, 4 Place d'Ostwald
F-67036 Strasbourg
Cedex 2
+33 3 8828 8400

ALTO Nederland B.V.
Postbus 65
3370 AB Hardinxveld-Giessendam
The Netherlands
+31 184 677 200

ALTO Sverige AB, Molndal (Sweden)
Aminogatan 18
Box 4029
S-431 04 Molndal
+46 31 706 73 00

ALTO Norge A/S, Oslo (Norway)
Bjernerudveien 24
N-1266
+47 2275 1770

Clarke® LIMITED U.S. WARRANTY

This Clarke Industrial/Commercial Product is warranted to be free from defects in materials and workmanship under normal use and service for a period of one year from the date of purchase, when operated and maintained in accordance with Clarke Maintenance and Operations instructions.

This warranty is extended only to the original purchaser for use of the product. It does not cover normal wear parts such as electrical cable, rubber parts, hoses and motor brushes.

If difficulty develops with the product, you should:

- a). Contact the nearest authorized Clarke repair location or contact the Clarke Service Operations Department, 2100 Highway 265, Springdale, Arkansas 72764, for the nearest authorized Clarke repair location. Only these locations are authorized to make repairs to the product under this warranty.
- b). Return the product to the nearest Clarke repair location. Transportation charges to and from the repair location must be prepaid by the purchaser.
- c). Clarke will repair the product and or replace any defective parts without charge within a reasonable time after receipt of the product.

Clarke's liability under this warranty is limited to repair of the product and/or replacement of parts and is given to purchaser in lieu of all other remedies, including INCIDENTAL AND CONSEQUENTIAL DAMAGES.

THERE ARE NO EXPRESS WARRANTIES OTHER THAN THOSE SPECIFIED HEREIN. THERE ARE NO WARRANTIES WHICH EXTEND BEYOND THE DESCRIPTION OF THE FACE HEREOF. NO WARRANTIES, INCLUDING BUT NOT LIMITED TO WARRANTY OF MERCHANTABILITY, SHALL BE IMPLIED. A warranty registration card is provided with your Clarke product. Return the card to assist Clarke in providing the performance you expect from your new floor machine.

Clarke®, 2100 Highway 265, Springdale, Arkansas 72764.

Clarke® POLYDUR® TANK EIGHT-YEAR GUARANTEE

Your new Image Carpet Extractor has a polydur Solution and Recovery Tanks. Polydur is a rotationally molded, low-density linear polyethylene that won't crack or dent, and withstands most corrosives and temperature extremes. Clarke backs up your Polydur tanks with an eight-year guarantee. If a tank breaks, cracks or leaks under normal use within eight years of the date of purchase, it will be replaced free.

**Clarke reserves the right to make
changes or improvements to its machine without notice.**

Always use genuine Clarke Parts for repair.

Clarke®

**2100 Highway 265
Springdale, Arkansas, 72764**